

**GOVERNMENT POLYTECHNIC
KENDRAPARA**

**DEPARTMENT OF CIVIL
ENGINEERING**



LECTURE NOTES

Year & Semester: 2nd Year, 3rd Semester

Subject code/Name -Th-2,

**GEOTECHNICAL
ENGINEERING**

By Jyotirmayee Samal, Sr Lect,Civil

CHAPTER-1

INTRODUCTION

1.0 INTRODUCTION OF SOIL

The word “Soil” is derived from the Latin word solium which, according to Webster’s dictionary, means the upper layer of the earth that may be dug or plowed specifically, the loose surface material of the earth in which plants grow. The above definition of soil is used in the field of agronomy where the main concern is in the use of soil for raising crops.

In geology, earth’s crust is assumed to consist of unconsolidated sediments, called mantle or regolith, overlying rocks. The term ‘soil’ is used for the upper layer of mantle which can support plants. The material which is called soil by the agronomist or the geologist is known as top soil in geotechnical engineering or soil engineering. The top soil contains a large quantity of organic matter and is not suitable as a construction material or as a foundation for structures. The top soil is removed from the earth’s surface before the construction of structures.

The term ‘soil’ in Soil Engineering is defined as an unconsolidated material, composed of solid particles, produced by the disintegration of rocks. The void space between the particles may contain air, water or both the solid particles may contain organic matter. The soil particles can be separated by such mechanical means as agitation in water.

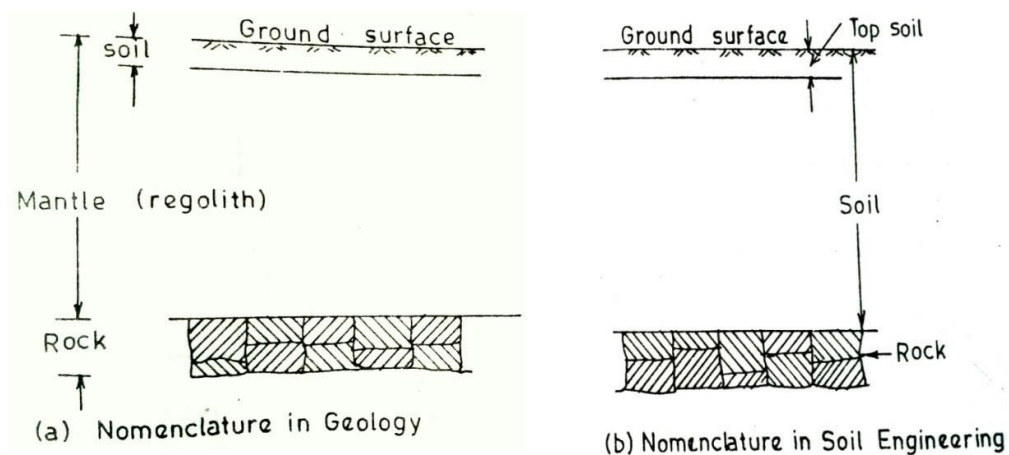

Fig. shows a cross-section through the earth’s surface, indicating the nomenclature used in geology, and in Soil Engineering.

1.1 SOIL AND SOIL ENGINEERING:-

The term 'soil mechanics' was coined by Dr. Karl Terzaghi in 1925 when his book *Erdbaumechanik* on the subject was published in German.

According to Terzaghi, 'Soil mechanics is the application of the laws of mechanics and hydraulics to engineering problems dealing with sediments and other unconsolidated accumulations of solid particles produced by the mechanical and chemical disintegration of rock, regarding of whether or not they contain an admixture of organic constituents.

Soil mechanics is, a branch of mechanics which deals with the action of forces on soil and with the flow of water in soil.

The soil consists of discrete solid particles which are neither strongly bonded as in solids nor they are as free as particles of fluids. Consequently, the behavior of soil is somewhat intermediate between that of a solid and a fluid. It is not, therefore, surprising that soil mechanics draws heavily from solid mechanics and fluid mechanics. As the soil is inherently a particulate system. Soil mechanics is also called particulate mechanics.

DEFINITION OF SOIL ENGINEERING AND GEOTECHNICAL ENGINEERING:-

Soil Engineering is an applied science dealing with the applications of principles of soil mechanics to practical problems. It has a much wider scope than soil mechanics, as it details with all engineering problems related with soils. It includes site investigations, design and construction of foundations, earth-retaining structures and earth structures.

1.2 SCOPE OF SOIL MECHANICS:-

Soil Engineering has vast application in the construction of various Civil Engineering works. Some of the important applications are as under.

- (1) **Foundations:**– Every civil engineering structure, whether it is a building, a bridge, or a dam, is founded on or below the surface of the earth. Foundations are required to transmit the load of the structure to soil safely and efficiently.

A foundation is termed shallow foundation when it transmitted the load to upper strata of earth. A foundation is called deep foundation when the load is transmitted to strata at considerable depth below the ground surface. Pile foundation is a type of deep foundation. Foundation engineering is an important branch of soil engineering.

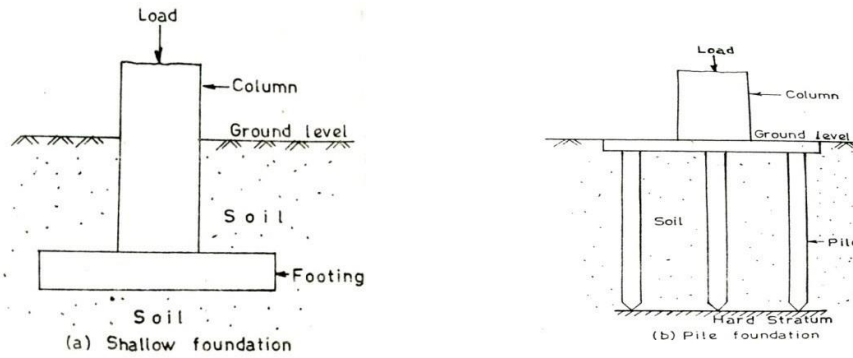

(2) **Retaining Structures:** – When sufficient space is not available for a mass of soil to spread and form a safe slope, a structure is required to retain the soil. An earth retaining structure is also required to keep the soil at different levels on its either side. The retaining structure may be rigid retaining wall or a sheet pile bulkhead which is relatively flexible (Fig. 1.3). Soil engineering gives the theories of earth pressure on retaining structures.

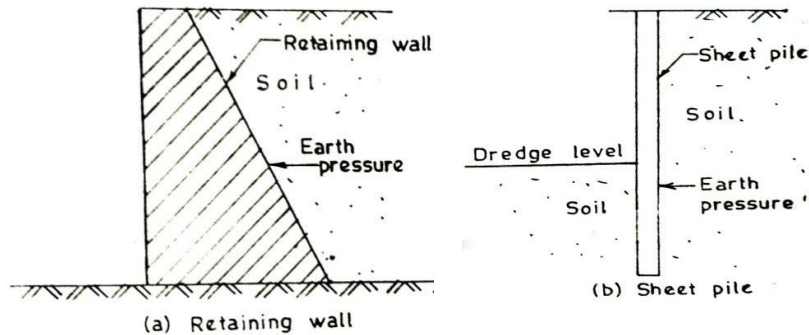

(3) **Stability of Slopes:** – If soil surface is not horizontal, there is a component of weight of the soil which tends to move it downward and thus causes instability of slope. The slopes may be natural or man-made Fig. 1.4 shows slopes in filling and cutting. Soil engineering provides the methods for checking the stability of slopes.

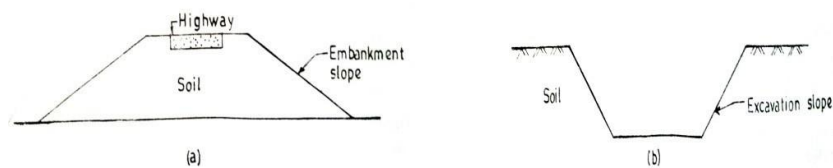

- (4) **Underground structures:** – The design and construction of underground structures, such as tunnels, shafts, and conduits, require evaluation of forces exerted by the soil on these structures. These forces are discussed in soil engineering. Fig. 1.5 shows a tunnel constructed below the ground surface and a conduit laid below the ground surface.

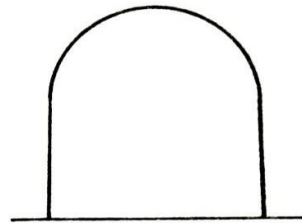

(a) Tunnel

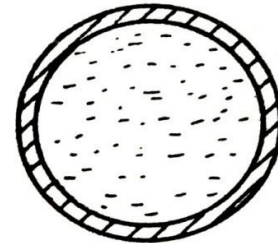

(b) Conduit

- (5) **Pavement Design:** – A pavement is hard rust placed on soil (sub grade) for the purpose of proving a smooth and strong surface on which vehicles can move. The pavement consists of surfacing, such as a bitumen layer, base and subtheme (Fig. 1.6). The behavior of sub grade under vicious conditions of loading and environment change is studied in soil engineering.

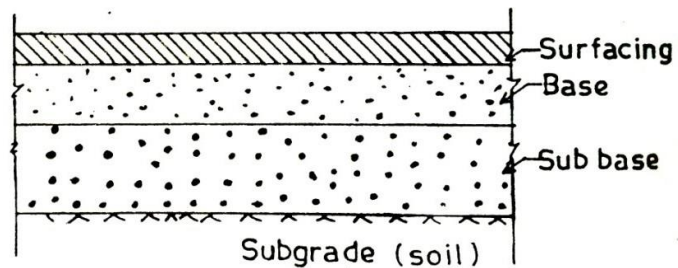

- (6) **Earth Dam:** – Earth dams are the structures in which soil is used as a construction material. The earth dams are built for creating water reservoirs. Since the failure of an earth dam may cause widespread catastrophe care is taken in its design and construction. It requires thorough knowledge at soil engineering.

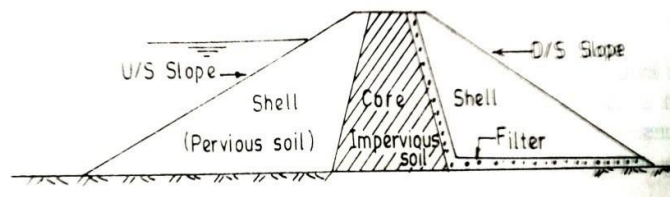

(7) **Miscellaneous soil:** - The geotechnical engineer has sometimes to tackle miscellaneous problems related with soil. Such as soil heave, soil subsidence, frost heave, shrinkage and swelling of soils.

CHAPTER-2

PRELIMINARY DEFINATION AND RELATIONSHIP

2.1 SOIL AS A THREE PHASE:

A soil mass consists of solid particles which form a porous structure. The voids in the soil mass may be filled with air, with water or partly with air and partly with water. In general, a soil mass consists of solid particles, water and air. The three constituents are blended together to form a complex material (Fig. 2.1. a) . However, for convenience, all the solid particles are segregated and placed in the lower layer of the three-phase diagram (Fig. 2.1b). Likewise, water and air particles are placed separately, as shown. The 3-phase diagram is also known as Block diagram.

It may be noted that the constituents cannot be

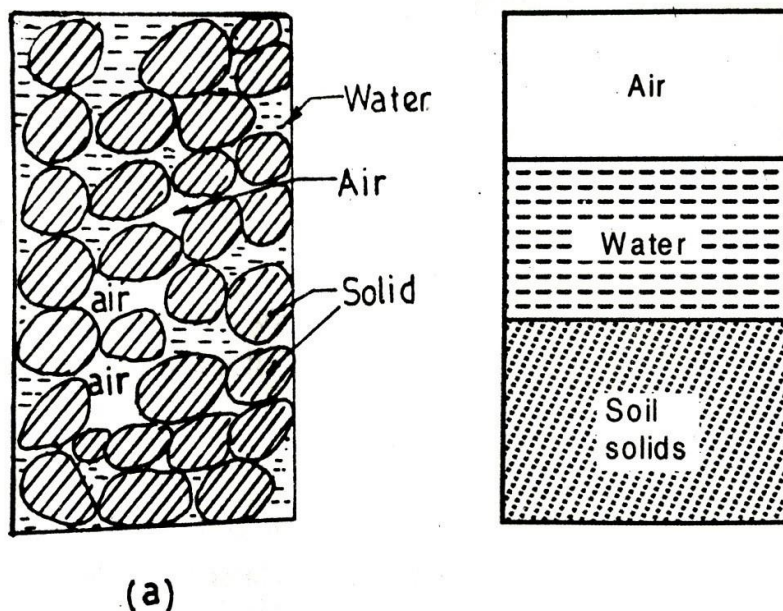

Actually segregated, as shown. A 3-phase diagram is an artifice used for easy understand and convenience in calculation.

Although the soil is a three-phase system, it becomes a two-phase system in the following two cases :(1) When the soil is absolutely dry, the water phase disappears (Fig. 2.2a). (2) When the soil is fully saturated there is no air phase (Fig.2.2b). It is the relative proportion of the three constituents and their interaction that governs the behavior and properties of soils. The phase diagram is a simple, diagrammatic representation of a real soil, It is extremely useful for studying the various terms used in soil engineering and their interrelationships.

In a 3-phase diagram it is conventional to write values on the left side and the mass on the right side (Fig.2.3a). The total soil mass is designated as V . It is equal to the sum of the volume of solids (V_s), the volume of water (V_w) and the volume of air (V_a). The volume of voids (V_v) is equal to the sum of the volumes of the water and air

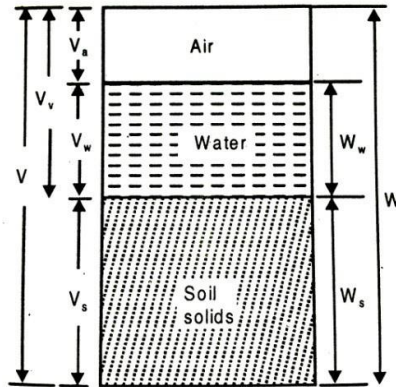

The soil mass of the soil... is represented as M . the mass of air (m_a) is very small and is neglected. Therefore, the total mass of the soil is equal to the mass of solids (M_s) and the mass of water (M_w). Fig.2.36 shows the 3-phase diagram in which the weights are written on the right side.

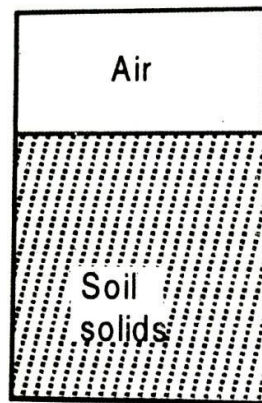

(a)

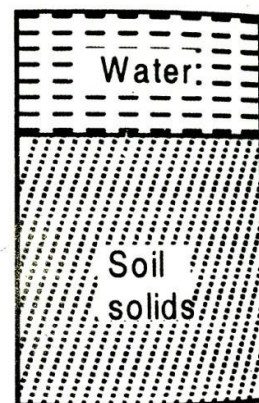

(b)

2.2 WEIGHT VOLUME RELATIONSHIPS:

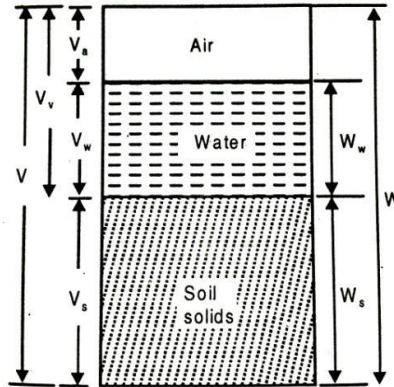

WATER CONTENT: - The water content (w) is defined as the ratio of the mass water to the mass of solids.

$$w = \frac{W_w}{W_s}$$

The water content is also known as the moisture content (m). It is expressed as a percentage, but whenever used in equation used as a decimal.

The water content of the fine-grained soils, such as silts and clays, is generally more than that of the coarse grained soils, such as gravels and sands.

The water content of some of the fine-grained soils may be even more than 100%, which indicates that more than 50% of the total mass is that of water. The water content of a soil is an important property.

SPECIFIC GRAVITY (G):-

The specific gravity of solid particles (G) is defined as the ratio of the mass of a given volume of solids to the mass of an equal volume of water at 4°C. Thus, the

$$\text{specific gravity is given by } G = \frac{\rho_s}{\rho_w}$$

*The mass density of water ρ_w at 4°C is one gm/ml, 1000 kg/m³ or 1 Mg/m³.

The specific gravity of solids for most natural soils falls in the general range of 2.65 to 2.80, the smaller values are for the coarse-grained soils. Table gives the average values of specific gravity for different soils. It may be mentioned that the specific gravity of different particles in a soil mass may not be the same. Whenever

the specific gravity of a soil mass is indicated, it is the average value of all the solid particles present in the soil mass. Specific gravity of solids is an important parameter. It is used for determination of void ratio and particle size.

Table: Typical Values of G

Sl.No.	Soil Type	Specific Gravity
1	Gravel	2.65-2.68
2	Sand	2.65-2.68
3	Sands	2.66-2.70
4	Silt	2.66-2.70
5	Inartistic Clays	2.68-2.80
6	Organic Soils	Variable, may fall below 2.00

Besides the following two terms related with the specific gravity are also used.

(1) **Mass Specific Gravity (G_m):**- It is defined as the ratio of the mass density of the soil to the mass density of water.

The value of the mass specific gravity of a soil is much smaller than the value of the specific gravity of solids.

The mass specific gravity is also known as the apparent specific gravity or the bulk specific gravity.

(2) **Absolute Specific Gravity (G_a):**- The soil solids are not perfect solids but contain voids. Some of these voids are permeable through which water can enter, whereas others are impermeable. Since the permeable voids get filled when the soil is wet, these are in reality a part of void space in the total mass and not apart of soil solids. If both the permeable and impermeable voids are excluded from the volume of solids, the remaining volume is the true or absolute volume of the solids.

The mass density of the absolute solids is used for the determination of the absolute specific gravity of solids.

VOIDS RATIO: - It is defined as the ratio of the volume of voids to the volume of solids.

$$e = \frac{V_v}{V_s}$$

The void ratio is expressed as a decimal, such as 0.4, 0.5, etc. For coarse-grained soils, the void ratio is generally smaller than that for fine-grained soils. For some soils, void ratio may have a value even greater than unity.

POROSITY:- It is defined as the ratio of the volume of voids to the total volume.

$$n = \frac{V_v}{V}$$

The Porosity is generally expressed as percentage. However, in equations, it is used as a ratio. For example; a porosity of 50% will be used as 0.5 in equations. The porosity of a soil cannot exceed 100% as it would mean V_v is greater than V , which is absurd. Porosity is also known as percentage voids.

Both porosity and void ratio are measures of the denseness (or looseness) of soils. As the soil becomes more and more dense, their values decrease. The term porosity is more commonly used in other disciplines such as agricultural engineering. In soil engineering, the term void ratio is more popular. It is more convenient to use void ratio than porosity. When the volume of a soil mass changes, only the numerator (i.e. V_v) in the void ratio changes and the denominator (i.e. V_s) remains constant. However, if the term porosity is used, both the numerator and the denominator change and it become inconvenient.

Relationship between the void ratio and the porosity as under.

$$\frac{1}{n} = \frac{V}{V_v} = \frac{V_v + V_s}{V_v}$$

$$\frac{1}{n} = 1 + \frac{1}{e} = \frac{1+e}{e}$$

$$n = \frac{e}{1+e} \text{-----(1)}$$

$$\frac{1}{e} = \frac{1}{n} - 1 = \frac{1-n}{n}$$

$$e = \frac{n}{1-n} \text{-----(2)}$$

The porosity should be expressed as a ratio (and not percentage).

PERCENTAGE OF AIR VOIDS (n_a):-

It is the ratio of the volume of air to the total volume.

$$n_a = \frac{V_a}{V}$$

It is represented as a percentage.

AIR CONTENT (a_c) : - Air content is defined as the ratio of the volume of air to the volume of voids.

$$a_c = \frac{V_a}{V_v}$$

The Air content is usually expressed as a percentage. Both air content and the percentage air voids are zero when the soil is saturated ($V_a = 0$).

Relationship between the percentage air voids and the air content can be obtained.

$$n_a = \frac{V_a}{V} = \frac{V_a}{V_v} \times \frac{V_v}{V}$$

$$n_a = n \times ac$$

Degree of Saturation (S) - The degree of saturation (S) is the ratio of the volume of water to the volume of voids. It is also represents as S_r .

$$S = \frac{V_w}{V_v}$$

The degree of saturation is generally expressed as a percentage.

It is equal to zero when the soil is absolutely dry and 100% when the soil is fully saturated. Degree of saturation is used as a decimal in expressions.

DENSITY INDEX:-

It the most important index property of a cohesion less soil.

It is also known as Density Index (I_D). It is also known as relative density or degree of density. It is used to express the relative compactness of a natural soil deposit.

It is the ratio of the difference between voids ratio of the soil in its loosest state and its natural voids ratio to the difference between voids ratio in the loosest and densest states.

$$I_D \text{ or } Dr = \frac{e_{\max} - e}{e_{\max} - e_{\min}} \times 100$$

Where e_{\max} = Maximum void ratio of the soil in the loosest condition.

e_{\min} = Minimum void ratio of the soil in the densest condition.

e = void ratio of the soil in the natural state.

e_{\max} will found out from γ_{\min} i,e in the loosest condition.

e_{\min} will found out from γ_{\max} i,e in the densest condition.

e will found out from γ_d i,e in the natural condition.

$$Dr = \frac{e_{\max} - e}{e_{\max} - e_{\min}} \times 100$$

$$Dr = \gamma_d = \frac{\frac{G_{yw}}{y_{min}} - 1}{1 + \frac{\gamma_v}{\gamma_s}} = \frac{G_{yw}}{1+e}$$

$$\gamma_d = \frac{G_{yw}}{1+e}$$

e_{max} The relative density of a soil gives a more clear idea of the denseness than does the void ratio.

BULK UNIT WEIGHT:-

The bulk unit weight is defined as the total weight per total volume.

$$\gamma = \frac{W}{V}$$

It is also known as total unit weight (γ_t) or wet unit weight.

In SI units it is express as N/mm^3 or KN/mm^3

DRY UNIT WEIGHT:-

The dry unit weight is defined as the weight of solids per total volume.

$$\gamma_d = \frac{W_s}{V}$$

SATURATED UNIT WEIGHT:-

The saturated unit weight is the bulk unit weight when the soil is fully saturated.

$$\gamma_{sat} = \frac{W_{sat}}{V}$$

SUBMERGED UNIT WEIGHT: -

When the soil exists below water than it is called submerged condition.

The submerged unit weight (γ') of the soil is defined as the submerged weight per total volume.

$$\gamma_{sub} = \frac{W_{sub}}{V}$$

Relation between G, S, e, γ & γ_w :-

$$\gamma = \frac{W}{V} = \frac{W_s + W_w}{V_s + V_v} = \frac{G V_s \gamma_w + V_v \gamma_w}{V_s + V_v}$$

Dividing V_s both numerator & denominator

$$\text{Or, } \gamma = \frac{G_{yw} + \left(\frac{\gamma_w}{\gamma_s}\right) \gamma_w}{1 + \frac{\gamma_v}{\gamma_s}} = \frac{\left(G + \frac{\gamma_w \gamma_v}{\gamma_s}\right) \gamma_w}{1 + \frac{\gamma_v}{\gamma_s}} = \frac{(G + S e) \gamma_w}{1 + \frac{\gamma_v}{\gamma_s}}$$

$$\text{Or, } \gamma = \frac{(G+S)e y_w}{1+e} \dots\dots\dots(3)$$

As the degree of saturation is 100% for a saturated soil, then the S= 1

$$\text{Or, } \gamma_{\text{sat}} = \frac{(G+e)y_w}{1+e} \dots\dots\dots(4)$$

$$\text{Similarly, } \gamma_d = \frac{W_s}{V} = \frac{W_s}{V_s+V_v} = \frac{G V_s y_w}{V_s+V_v}$$

Dividing V_s both numerator & denominator

$$\gamma_d = \frac{G y_w}{1+\gamma_s} = \frac{G y_w}{1+e} \dots\dots\dots(5)$$

We know that $\gamma_{\text{sub}} = \gamma_{\text{sat}} - \gamma_w$

$$\begin{aligned} &= \frac{(G+e)y_w}{1+e} - \gamma_w = \frac{(G-1)y_w}{1+e} \\ \gamma_{\text{sub}} &= \frac{(G-1)y_w}{1+e} \dots\dots\dots(6) \end{aligned}$$

Relation Between e, w, G & S :-

$$\text{We know that } w = \frac{W_w}{W_s} \quad (\text{As } \gamma_w = \frac{W_w}{V_w} \text{ \& } \gamma_s = \frac{W_s}{V_s})$$

$$= \frac{V_w y_w}{V_s y_s}$$

$$= \frac{V_w}{V_v} \times \frac{V_v}{V_s} \times \frac{y_w}{y_s}$$

$$= S \cdot e \cdot \frac{1}{G} \quad (\text{As } S = \frac{V_w}{V_v}, e = \frac{V_v}{V_s} \text{ \& } G = \frac{y_s}{y_w})$$

$$w \cdot G = S \cdot e$$

$$e = \frac{w \cdot G}{S}$$

Relation between e, S & n_a :-

$$n_a = \frac{V_a}{V} = \frac{V_v - V_w}{V_v + V_s}$$

Dividing V_s both numerator & denominator

$$= \frac{\frac{V_v}{V_s} - \frac{V_w}{V_s}}{\frac{V_v}{V_s} + \frac{V_s}{V_s}} = \frac{\frac{V_v}{V_s} - \frac{V_w}{V_s}}{\frac{V_v}{V_s} + 1} = \frac{e - S}{e + 1}$$

$$n_a = \frac{(1-S)e}{1+e} \dots\dots\dots(7)$$

Relation between S & a_c :-

$$a_c = \frac{V_a}{V_v} = \frac{V_v - V_w}{V_v} = 1 - \frac{V_w}{V_v} = 1 - S \dots\dots\dots(8)$$

Relation between Na, a_c & n:-

$$n_a = \frac{V_a}{V} = \frac{V_a}{V_v} \cdot \frac{V_v}{V} = a_c \cdot n \dots\dots\dots (9)$$

Relation between G, n_a, e, γ_d & γ_w :-

$$V = V_s + V_v + V_a$$

$$1 = \frac{V_s}{V} + \frac{V_v}{V} + \frac{V_a}{V} = \frac{V_s}{V} + \frac{V_v}{V} + n_a$$

$$1 - n_a = \frac{V_s}{V} + \frac{V_v}{V} = \frac{W_s/G\gamma_w}{V} + \frac{W_w/\gamma_w}{V}$$

$$= \frac{\gamma_d}{G\gamma_w} + \frac{wW_s/\gamma_w}{V}$$

$$= \frac{\gamma_d}{G\gamma_w} + \frac{w\gamma_d}{\gamma_w} = \left(\frac{1}{G} + w\right) \cdot \frac{\gamma_d}{\gamma_w}$$

$$\gamma_d = \frac{(1 - n_a) G\gamma_w}{1 + wG} \dots\dots\dots(10)$$

Relation between w, γ_d & γ_s :-

$$w = \frac{W_w}{W_s}$$

$$\text{Or, } 1 + w = 1 + \frac{W_w}{W_s} = \frac{W_s + W_w}{W_s}$$

$$\text{Or, } W_s = \frac{W}{1 + w}$$

$$\text{Or, } \gamma_{d.v} = \frac{W}{1 + w}$$

$$\text{Or, } \gamma_{d.} = \frac{W}{(1 + w)V} = \frac{y}{(1 + w)}$$

$$\text{Or, } \gamma_{d.} = \frac{y}{(1 + w)} \dots\dots\dots(11)$$

CHAPTER-3

DETERMINATION OF INDEX PROPERTIES

WATER CONTENT DETERMINATION:

- The water content of a soil is an important parameter that controls its behaviour.
- It is a quantitative measure of the wetness of a soil mass.
- The water content of soil mass can be determined by the following methods:
 1. Oven drying method
 2. Pycnometer method

(1) Oven drying method:

- The oven drying method is a standard laboratory method and this is a very accurate method.
- In this method the soil sample is taken in a small, non-corrodible, air tight container.
- The mass of the sample and that of the container are obtained using an accurate weighing balance.
- The soil sample in the container is then dried in an oven at a temperature of $110^{\circ}\text{C} \pm 5^{\circ}\text{C}$ for 24 hours.
- The water content of the soil sample is then calculated from the following equation:

$$W = M_w/M_s \\ = \frac{M_2 - M_3}{M_3 - M_1} \times 100$$

Where M_1 = mass of container with lid

M_2 = mass of container, lid and wet soil

M_3 = mass of container, lid and dry soil

(2) Pycnometer method:

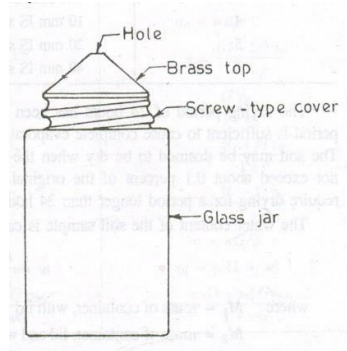

Figure 3.1
Pycnometer

- A pycnometer is a glass jar of about 1 litre capacity and fitted with a brass conical cap by means of screw type cover.
- The cap has a small hole of 6 mm diameter at its apex. A rubber or fibre washer is placed between the cap and the jar to prevent leakage.
- There is a mark on the cap and also on the jar. The cap is screwed down to the same mark such that the volume of the pycnometer used in the calculations remains constant.
- The pycnometer method for the determination of water content can be used only if the specific gravity of solid particle is known.
- A sample of wet soil about 200 to 400 gm is taken in the pycnometer and weighed.
- Water is then added to the soil in the pycnometer to make it about half full.
- The contents are thoroughly mixed using a glass rod to remove the entrapped air. More and more water is added and stirring process continued till the pycnometer is filled flush with the hole in the conical cap.
- The pycnometer is wiped dry and weighed.
- The pycnometer is then completely emptied. It is washed and filled with water, flush with the top hole.
- The pycnometer is wiped dry and weighed.
- Let M_1 = mass of pycnometer

M_2 = mass of pycnometer + wet soil

M_3 = mass of pycnometer + wet soil + water

M_4 = mass of pycnometer filled with water only

The mass M_4 is equal to mass M_3 minus the mass of solids M_s plus the mass of an equal volume of water.

$$M_4 = M_3 - M_s + \frac{M_s}{G} \rho_w$$

$$M_4 = M_3 - M_s + \frac{M_s}{G}$$

$$= M_3 - M_s \left(1 - \frac{1}{G}\right)$$

$$M_s = (M_3 - M_4) \left(\frac{G}{G-1}\right)$$

Mass of wet soil = $M_2 - M_1$

$$\text{Therefore mass of water } M_w = (M_2 - M_1) - (M_3 - M_4) \left(\frac{G}{G-1}\right)$$

$$w = \frac{M_w}{M_s} \times 100$$

$$= \left[\left(\frac{M_2 - M_1}{M_3 - M_4} \right) \left(\frac{G-1}{G} \right) - 1 \right] \times 100$$

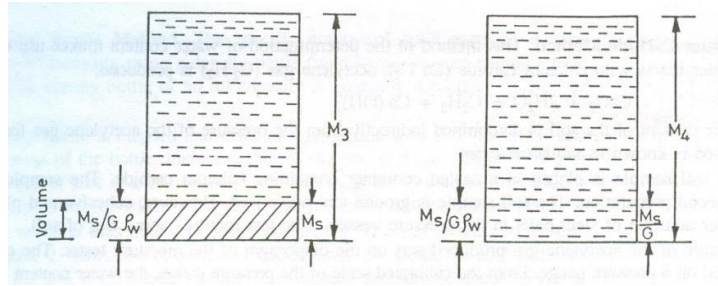

Figure 3.2

Pycnometer method Derivation

- This method for the determination of the water content is suitable for coarse grained soils from which the entrapped air can be easily removed.

SPECIFIC GRAVITY:

- The specific gravity of soil solids can be determined by :
 - (i) A 50 ml density bottle or
 - (ii) A 500 ml flask or
 - (iii) A pycnometer
- The density bottle method is the most accurate and is suitable for all types of soil.

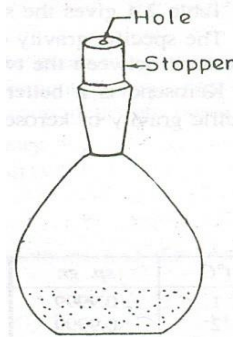

Figure 3.3

Density bottle

- The flask or pycnometer is used only for coarse grained soils.
- The density bottle method is the standard method used in the laboratory.
- In the above three methods the sequence of observation is same.
- The mass M_1 of the empty, dry, bottle is first taken.
- A sample of oven dried soil cooled in a desiccator is put in the bottle and the mass M_2 is taken.

- The bottle is then filled with distilled water gradually removing the entrapped air either by applying vacuum or by shaking the bottle.
- The mass M_3 of the bottle, soil and water is taken.
- Finally, the bottle is emptied completely and thoroughly washed and clean water is filled to the top and the mass M_4 is taken.
- If the mass of solid M_s is subtracted from M_3 and replaced by the mass of water equal to the volume of solid the mass M_4 is obtained.

$$M_4 = M_3 - M_s + \frac{M_s \rho_w}{G \rho_w}$$

$$\text{Or, } M_s \left(1 - \frac{1}{G}\right) = M_3 - M_4$$

$$\text{But } M_s = M_2 - M_1$$

$$\text{Therefore } (M_2 - M_1) \left(1 - \frac{1}{G}\right) = M_3 - M_4$$

$$\text{Or } \frac{1}{G} (M_2 - M_1) = (M_2 - M_1) - (M_3 - M_4)$$

$$\text{Or } G = \frac{M_2 - M_1}{(M_2 - M_1) - (M_3 - M_4)} \text{ ----- (i)}$$

$$\text{Alternatively } G = \frac{M_s}{M_s + M_4 - M_3} \text{ ----- (ii)}$$

Equation (1) gives the specific gravity of solids at the temperature at which the test was conducted.

Specific gravity of solids is generally reported at 27°C or at 4°C. The specific gravity at 27°C and 4°C can be determined from the following equation

$$G_{27} = G_t \times \frac{\text{specific gravity of water at } t^\circ\text{C}}{\text{specific gravity of water at } 27^\circ\text{C}}$$

$$\text{And } G_4 = G_t \times \text{specific gravity of water at } t^\circ\text{C}$$

Where G_{27} = specific gravity of particles at 27°C

G_4 = specific gravity of particles at 4°C

G_t = specific gravity of particles at $t^\circ\text{C}$

PARTICLE SIZE DISTRIBUTION:

- The percentage of various sizes of particle in a given dry soil sample is found by a particle size analysis or mechanical analysis.
- Mechanical analysis means separation of a soil into its different size fractions.
- The mechanical analysis is performed in two stages
 - (i) Sieve analysis
 - (ii) Sedimentation analysis or wet mechanical analysis
- The first stage is meant for coarse grained soil only while the second stage is performed for fine grained soils.
- In general a soil sample may contain both coarse grained particles as well as fine Particles and hence both the stages of the mechanical analysis may be necessary.

Sieve Analysis:

- In the Indian standard the sieves are designated by the size of the aperture in mm.
- The sieve analysis can be divided into two parts i.e the coarse analysis and fine analysis.
- An oven dried sample of soil is separated into two fractions by sieving it through a 4.75 mm I.S sieve.
- The portion retained on it is termed as the gravel fraction and is kept for the coarse analysis while the portion passing through it is subjected to fine sieve analysis.
- The following sets of sieves are used for coarse sieve analysis: IS: 100, 63, 20, 10 and 4.75 mm.
- The sieves used for fine sieve analysis are : IS : 2 mm, 1.0 mm, 600, 425, 300, 212, 150 and 75 micron.
- Sieving is performed by arranging the various sieves one over the other in the order of their mesh openings – the largest aperture sieve being kept at the top and the smallest aperture sieve at the bottom.
- A receiver is kept at the bottom and a cover is kept at the top of whole assembly.
- The soil sample is put on the top sieve and the whole assembly is fitted on a sieve shaking machine.
- The amount of shaking depends upon the shape and the number of particles.
- At least 10 minutes of shaking is desirable for soils with small particles.
- The portion of the soil sample retained on each sieve is weighed.
- The percentage of soil retained on each sieve is calculated on the basis of the total mass of soil sample taken and from this percentage passing through each sieve is calculated.

Sedimentation Analysis:

- In the wet mechanical analysis or sedimentation analysis the soil fraction finer than 75 micron size is kept in suspension in a liquid (usually water) medium.
- The analysis is based on stokes law according to which the velocity at which grains settle out of suspension, all other factors being equal, is dependent upon the shape, weight and size of the grain.
- However in the usual analysis it is assumed that the soil particles are spherical and -have the same specific gravity.
- With this assumption the coarser particles settle more quickly than the finer ones.

- If v is the terminal velocity of sinking of a spherical particle it is given by

$$v = \frac{2r^2}{9} \frac{\gamma_s - \gamma_w}{\eta}$$

$$\text{Or } v = \frac{1 D^2}{18} \frac{\gamma_s - \gamma_w}{\eta}$$

Where r = radius of the spherical particle (m)

D = diameter of the spherical particle (m)

v = terminal velocity (m/sec)

γ_s = unit weight of particles (KN/m³)

γ_w = unit weight of liquid or water (KN/m³)

= viscosity of liquid or water (KN s/m²) = μ/g

μ = viscosity in absolute units of poise

g = acceleration due to gravity

- If water is used as the medium for suspension γ_w is equal to 9.81 KN/m³. Similarly

$\gamma_s = G\gamma_w$. Substituting this we get

$$v = \frac{1}{18} \frac{D^2 (G-1) \gamma_w}{\eta}$$

The above formula should be expressed in the consistent units of meters, seconds and kilo newton.

If the diameter (D) of the particles is in mm we have

$$v = \frac{1}{18} \frac{(D/1000)^2 (G-1) \gamma_w}{\eta}$$

$$= \frac{D^2 \gamma_w (G-1)}{18 \times 10^6 \eta}$$

Taking $\gamma_w = 9.81$ KN/m³

$$\text{We get } v = \frac{D^2 (G-1)}{1.835 \times 10^6 \eta}$$

$$D = \sqrt{\frac{18 \times 10^6 \eta v}{(G-1) \gamma_w}} \text{ mm}$$

$$D = 1355 \sqrt{\frac{\eta v}{G-1}} \text{ mm}$$

It should be noted that 1 poise is equivalent to 0.1 Ns/m² or to 10⁻⁴ KN s/m²

If a particle of diameter D mm falls through a height of H_c cm in t minutes.

$$v = H_c / 60t \text{ cm/sec}$$

$$= H_c / 6000t \text{ m/sec}$$

Substituting in the above equation we get

$$D = \sqrt{\frac{18 \times 10^6 \eta H_e}{(G-1)\gamma_w \times 6000t}}$$

$$= \sqrt{\frac{3000\eta}{(G-1)\gamma_w}} \sqrt{\frac{H_e}{t}}$$

$$D = 10^{-5} F \sqrt{\frac{H_e}{t}}$$

Where $F = 10^5 \sqrt{\frac{3000\eta}{(G-1)\gamma_w}}$ is a constant factor for given values of η and G .

At 27°C, the viscosity μ of the distilled water is approximately 0.00855 poise.

Since 1 poise is equivalent to 10^{-4} KN-s/m²

We have $\eta = 0.00855 \times 10^{-4}$ KN-s/m²

Taking an average value of $G = 2.68$

Putting these value in $v = \frac{D^2 (G-1)}{1.835 \times 10^6 \eta}$

$$\text{We get } v = \frac{D^2 (9.81)(2.68-1)}{18 \times 10^6 \times 0.00855 \times 10^{-4}}$$

$$= 1.077 D^2 \text{ (m/sec)}$$

This is an approximate version of Stoke's law and can be easily remembered for rough determination.

- The sedimentation analysis is done either with the help of hydrometer or a pipette.
- In both the methods a suitable amount of oven dried soil sample, finer than 75 micron size is mixed with a given volume V of distilled water.
- The mixture is shaken thoroughly and the test is started by keeping the jar containing soil water mixture, vertical.
- At the commencement of sedimentation test soil particles are assumed to be uniformly distributed throughout the suspension.
- After any time interval t , if a sample of soil suspension is taken from a height H_e (measured from the top level of suspension), only those particles will remain in the suspension which have not settled during this time interval.

The diameter of those particles which are finer than those which have already settled

can be found from $D = 10^{-5} F \sqrt{\frac{H_e}{t}}$

- The greater the time interval t allowed for suspension to settle, the finer are the particles sizes retained at this depth H_e .
- Hence sampling at different time intervals, at this sampling depth H_e would give the content of particles of different sizes.
- If at any time interval t , M_D is the mass, per ml, of all particles smaller than the diameter D still in suspension at the depth H_e the percentage finer than D is given by

$$N = \frac{M_D}{M_d/V} \times 100$$

Where N = percentage finer than the diameter D

M_d = total dry mass of all particles put in the suspension

V = volume of suspension

Thus with the help of above equations we can get various diameter D and the percentage of particles finer ($N\%$) than this diameter.

Limitation of sedimentation analysis:

- (1) The sedimentation analysis gives the particle size in terms of equivalent diameter, which is less than the particle size given sieve analysis. The soil particles are not spherical. The equivalent diameter is close to the thickness (smallest dimension) rather than the length or width.
- (2) As the specific gravity of solids for different particles is different, the use of an average value of G is a source of error. However as the variation of the values of G is small the error is negligible.
- (3) Stokes law is applicable only when the liquid is infinite. The presence of walls of the jar affects the result to some extent.
- (4) In stokes law it has been assumed that only one sphere settle and there is no interface from other spheres. In the sedimentation analysis as many particles settle simultaneously there is some interface.
- (5) The sedimentation analysis cannot be used for particles larger than 0.2 mm as turbulent conditions develop and stokes law is not applicable.
- (6) The sedimentation method is not applicable for particles smaller than 0.2μ because Brownian movement takes place and the particles do not as per Stokes law.

PIPETTE METHOD:

- The pipette method is the standard sedimentation method used in the laboratory.
- The equipment consists of a pipette, a jar and a number of sampling bottles.
- Generally a boiling tube of 500 ml capacity is used in place of a jar.

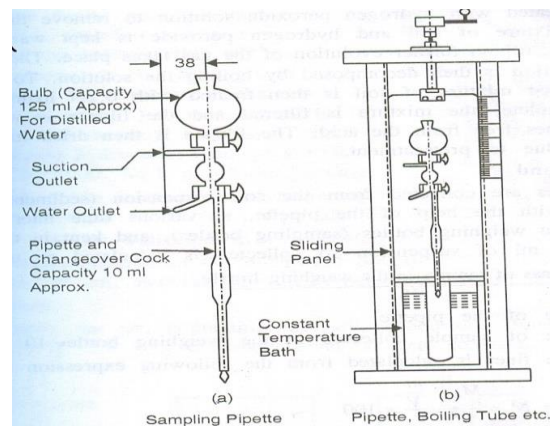

Figure 3.4

- The figure shows a pipette for extracting samples from the jar from a desired depth (H_e).
- The pipette consists of a 125 ml bulb with stop cock for keeping distilled water, a three way stop cock, suction and waste water outlets, sampling pipette of 10 ml capacity.
- The method consists in drawing off samples of soil suspension, 10 ml in volume, by means of this pipette from a depth of 10 cm (H_e) at various time intervals after the commencement of the sedimentation.
- The recommended time intervals are: ½, 1, 2, 4, 8, 15 and 30 minutes and 1, 2, 4, 8, 16 and 24 hours reckoned from the commencement of the test.
- The pipette should be inserted in the boiling tube about 25 seconds before the selected time interval and the time taken for sucking the sample should not be more than 10 to 20 seconds.
- Each sample so taken is transferred into suitable sampling bottles and dried in an oven.
- The mass M_D of solids per ml of suspension is thus found by taking the dry mass and dividing it by 10.

Method of preparing soil suspension:

- In the sedimentation analysis only those particles which are finer than 75 micron size are included.
- About 12 to 30 gm of oven dried sample is accurately weighed and mixed with distilled water in a dish or beaker to form a smooth thin paste. To have proper dispersion of soil a dispersing agent is added to the soil. Some of the common dispersing agents are sodium oxalate, sodium silicate and sodium polyphosphate compounds such as tetra sodium pyrophosphate, sodium hexametaphosphate and sodium tripolyphosphate.
- IS 2720 recommends the use of dispersing solution containing 33 gm of the sodium hexametaphosphate and 7 g of sodium carbonate in distilled water to make one litre of solution.
- 25 ml of this solution is added to the dish (containing the soil and distilled water) and the mixture is warmed gently for about 10 minutes.
- The contents are then transferred to the cup of a mechanical mixer, using a jet of distilled water to wash all traces of the soil out of the evaporating dish.
- The soil suspension is then stirred well for 15 minutes.
- The suspension is then washed through 75 micron IS sieve, using jet of distilled water and the suspension, which has passed through the sieve, is transferred to the 500 ml capacity boiling tube (sedimentation tube).
- The tube is then filled to the 500 ml mark by adding distilled water.

- The tube is then put in a constant temperature water bath.
- When the temperature is then tube has been stabilised to the temperature of the bath, the soil suspension is thoroughly shaken by inverting the tube several times, and then replaced in the bath.
- The stop was then started and the soil samples are collected at various time intervals with the help of pipette.

Calculation of D and N:

- 10 ml samples are collected from the soil suspension (sedimentation tube) from a depth of 10 cm, with the help of the pipette at various time intervals.
- The samples are collected into the weighing bottles (sampling bottles) and kept in the oven for drying.
- The mass M_D , per ml of suspension so collected is calculated as under :

M_D = dry mass of sample in the weighing bottle/ V_P

Where V_P = volume of the pipette

= volume of sample collected in the weighing bottle = 10 ml

The percentage finer is calculated from the following expression

$$N' = \frac{M_D - \frac{m}{7}}{\frac{M_D}{7}} \times 100$$

Where m = mass of dispersing agent present in the in the total suspension of volume V

V = volume of suspension = 500 ml

N' = percentage finer based on M_D

HYDROMETER METHOD:

- The hydrometer method of sedimentation analysis differs from the pipette analysis in the method of taking observation.
- In the pipette analysis the mass M_D per ml of suspension is found directly by collecting a 10 ml sample of soil suspension from the sampling depth H_e . However in the hydrometer analysis M_D is computed indirectly by reading the density of the soil suspension at a depth H_e at various time intervals.
- In the pipette test the sampling depth H_e is kept constant while in the hydrometer test, the sampling depth H_e goes on increasing as the particles settle with the increase in the time interval. It is therefore necessary to calibrate the hydrometer.

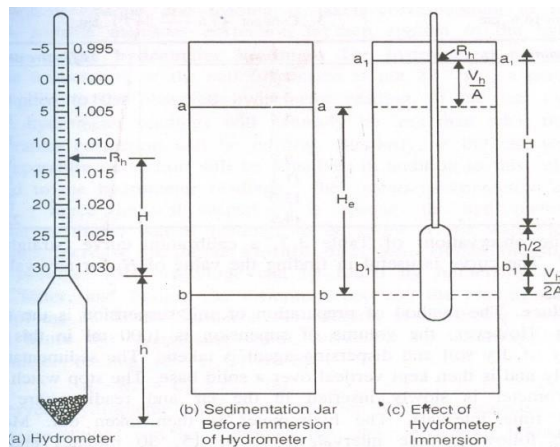

Figure 3.5

Calibration of hydrometer:

- The readings on the hydrometer stem give the density of the soil suspension situated at the centre of the bulb at any time.
- For convenience, the hydrometer readings are recorded after subtracting 1 and multiplying the remaining digits by 1000. Such a reduced reading is designated as R_h .
- For example, if the density reading at the intersection of horizontal surface of soil suspension with the stem is 1.010, it is recorded as 10 i.e $R_h = 10$.
- As indicated in figure the hydrometer reading R_h is increase in the downward direction towards the hydrometer bulb.
- Let H be the height in cm between any hydrometer reading R_h and the neck, and h the height of the bulb.
- Figure (b) shows the jar containing the soil suspension.
- When the hydrometer is immersed in the jar as shown in figure (c) the water level aa rises to a_1a_1 , the rise being equal to the volume V_h of the hydrometer divided by the internal area of cross section A of the jar.
- Similarly the level bb rises to b_1b_1 , where bb is the level situated at a depth H_e below the top level aa , at which the density measurements of the soil suspension are being taken.
- The rise between bb and b_1b_1 will be approximately equal to $V_h/2A$.
- The level b_1b_1 is now corresponding to the centre of the bulb, but the soil particles at b_1b_1 are of the same concentration as they were at bb .
- Therefore we have

$$H_e = \left(H + \frac{h}{2} + \frac{V_h}{2A} \right) - \frac{V_h}{A}$$

$$= H + \frac{1}{2} \left(h - \frac{V_h}{A} \right)$$

- In the above expression there are two variables: the effective depth H_e and the depth H which depends upon the hydrometer reading R_h .
- Therefore by selecting various hydrometer reading R_h , the depth H can be measured with the help of an accurate scale and the corresponding depth H_e can be found.
- The height h of the bulb is constant. Similarly V_h and A are constant.
- To find the volume of the hydrometer it is weighed accurately. The mass of the hydrometer in grams give the volume of the hydrometer in millilitres.

Test procedure:

- The method of preparation of soil suspension is the same as indicated in the pipette test.
- However the volume of suspension is 1000 ml in this case and hence doubles the quantity of dry soil and dispersing agent is taken.
- The sedimentation jar is shaken vigorously and is then kept vertical over a solid base.
- The stop watch is started simultaneously.
- The hydrometer is slowly inserted in the jar and readings are taken at ½, 1 and 2 minutes time interval. The hydrometer is then taken out.
- More readings are then taken at the following time intervals: 4, 8, 15, 30 minutes and 1, 2, 4 hours etc.
- To take the reading, the hydrometer is inserted about 30 seconds before the given time interval, so that it is stable at the time when the reading is to be taken.
- Since the soil suspension is opaque the reading is taken corresponding to the upper level of the meniscus.

Correction to the hydrometer reading:

The hydrometer readings are corrected as under:

(i) Meniscus correction:

- Since the suspension is opaque, the observations are taken at the top of the meniscus.
- The meniscus correction is equal to the reading between the top of the meniscus and the level of the suspension.
- As the marking on the stem increase downward the correction is positive.
- The meniscus correction (C_m) is determined from the readings at the top and bottom of meniscus in the comparison cylinder. The meniscus correction is constant for a hydrometer.
- If R_h' is the hydrometer reading of the suspension at a particular time, the corrected hydrometer R_h reading is given by

$$R_h = R_h' + C_m$$

(ii) Temperature correction:

- The hydrometer is generally calibrated at 27°C. If the temperature of the suspension is different from 27°C a temperature correction (C_t) is required for the hydrometer reading.
- If the temperature is more than 27°C, the suspension is lighter and the actual reading will be less than the corrected reading. The temperature correction is positive.
- On the other hand, if the temperature is less than 27°C the temperature correction is negative.

(iii) Dispersion agent correction:

- Addition of the dispersing agent to the soil suspension causes an increase in the specific gravity of the suspension.
- Therefore the dispersing agent correction is always negative.
- The dispersing agent correction (C_d) can be determined by noting the hydrometer reading in clear water and again in the same water after adding the dispersing agent.
- Thus the corrected reading R can be obtained from the observed reading R_h' as under

$$R = R_h' + C_m \pm C_t - C_d$$

(iv) Composite Correction:

- Instead of finding the correction individually, it is convenient to find one composite correction.
- The composite correction (C) is the algebraic sum of all the correction.

Thus $R = R_h' \pm C$

- The composite correction is found directly from the readings taken in a comparison cylinder, which has distilled water and the dispersing agent in the same concentration and has the same temperature.

Computation of D and N:

- The particle size D is calculated from the following formula

$$D = 10^{-5} F \sqrt{\frac{H_e}{t}}$$

- To compute the percentage of the soil finer than this diameter, the mass M_D per ml of suspension at effective depth H_e is first computed as under
- Since the hydrometer readings have been recorded by subtracting 1 from the density (ρ) readings and multiplying them by 1000, we have

$$R = (\rho - 1)1000$$

Or, $p = 1 + R/1000$ ----- (i)

Where p is the density reading actually marked on the hydrometer and R is the hydrometer reading corrected for the composite correction.

- Now let us consider 1 ml of soil suspension at a time interval t at the effective depth H_e . If M_D is the mass of solids in this 1 ml suspension the mass of water in it will be

$1 - M_D/G$

Total mass of 1 ml suspension = $1 - \frac{M_D}{G} + M_D$

Hence density of the suspension = $1 - \frac{M_D}{G} + M_D$ ----- (ii)

Equating equation (i) and (ii) we get

$1 + R/1000 = 1 - \frac{M_D}{G} + M_D$

$M_D = \frac{R}{1000} \left(\frac{G}{G-1} \right)$

Where G = specific gravity of soil solids

Substituting these values in equation $N = \frac{M_D}{M_{D/7}} \times 100$

We get $N' = \frac{R}{1000} \left(\frac{G}{G-1} \right) \times 100$

Taking $V = 1000$ ml we get

$N' = \frac{100GR}{Md(G-1)}$

Where N' = percentage finer with respect to M_d

Thus for various values of R , N' can be calculated

- For a combined sieve and sedimentation analysis if M is the total dry mass of soil originally taken (before sieving it over 2mm sieve) the overall percentage finer N is given by

$N = N' \times \frac{M'}{M}$

Where M' = cumulative mass passing 2 mm sieve

M = total dry mass of soil sample

If the soil sample does not contain particles coarser than 2 mm size, N and N' will be equal.

CONSISTENCY OF SOIL:

- Consistency means the relative ease with which soil can be deformed.
- Consistency denotes degree of firmness of the soil which may be termed as soft, firm, stiff or hard.
- Fine grained soil may be mixed with water to form a plastic paste which can be moulded into any form by pressure.
- The addition of water reduces the cohesion making the soil still easier to mould.
- Further addition of water reduces the until the material no longer retains its shape under its own weight, but flows as a liquid.

- Enough water may be added until the soil grains are dispersed in a suspension.
- If water is evaporated from such a soil suspension the soil passes through various stages or states of consistency.
- Swedish agriculturist Atterberg divided the entire range from liquid to solid state into four stages :
 - (i) Liquid state
 - (ii) Plastic state
 - (iii) Semi – solid state
 - (iv) Solid state

He sets arbitrary limits known as consistency limit or Atterberg limit for these divisions in terms of water content

- Thus consistency limits are the water content at which the soil mass passes from one state to the next.
- The Atterberg limits which are most useful are :
 - (i) Liquid limit
 - (ii) Plastic limit
 - (iii) Shrinkage limit

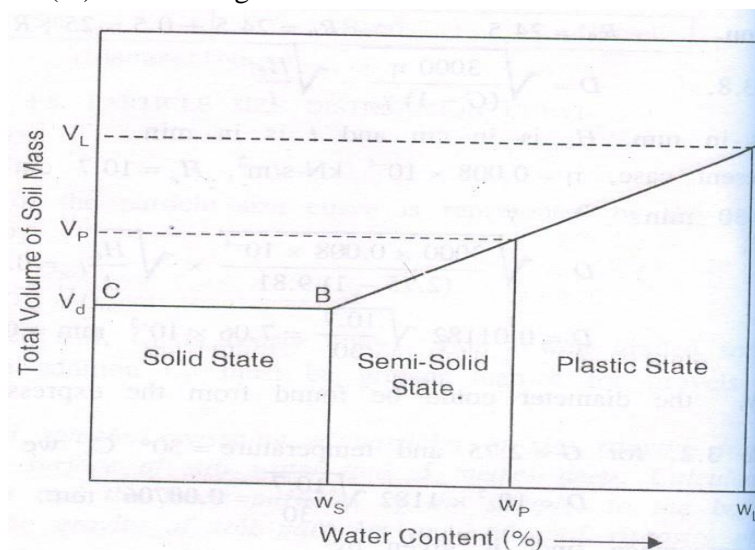

Figure 3.6

Different states of soil

Liquid Limit:

- Liquid limit is the water content corresponding to the arbitrary limit between liquid and plastic state of consistency of a soil.
- It is defined as the minimum water content at which the soil is still in the liquid state but has a small shearing strength against flowing which can be measured by standard available means.

- With reference to the standard liquid limit device, it is defined as the minimum water content at which a part of soil cut by a groove of standard dimension, will flow together for a distance of 12 mm under an impact of 25 blows in the device.

Plastic limit:

- Plastic limit is the water content corresponding to an arbitrary limit between the plastic and the semi-solid state of consistency of a soil.
- It is defined as the minimum water content at which a soil will just begin to crumble when rolled into a thread approximately 3 mm in diameter.

Shrinkage limit:

- Shrinkage limit is defined as the maximum water content at which a reduction in water content will not cause a decrease in the volume of a soil mass.
- It is lowest water content at which a soil can still be completely saturated.

Plasticity Index:

- The range of consistency within which a soil exhibit plastic properties is called plastic range and is indicated by plasticity index.
- Plasticity index is defined as the numerical difference between the liquid limit and the plastic limit of a soil.

$$I_p = w_l - w_p$$

- When plastic limit cannot be determined , the plasticity index is reported as NP (Non plastic).
- When the plastic limit is equal to or greater than the liquid limit the plasticity index is reported as zero.

Plasticity:

- Plasticity is defined as that property of a soil which allows it to be deformed rapidly, without rupture, without elastic rebound and without volume change.

Consistency Index:

- The consistency index or the relative consistency is defined as the ratio of the liquid limit minus the natural water content to the plasticity index of soil

$$I_c = \frac{w_l - w}{I_p}$$

Where w is the natural water content of the soil

- If consistency index of a soil is equal to unity, it is at the plastic limit.
- Similarly a soil with I_c equal to zero is at its liquid limit.
- If I_c exceeds unity the soil is in a semi – solid state and will be stiff.

- A negative consistency index indicates that the soil has natural water content greater than the liquid limit and hence behaves just like a liquid.

Liquidity index:

- The liquidity index or water plasticity ratio is the ratio, expressed as a percentage, of the natural water content of a soil minus its plastic limit to its plasticity index:

$$I_l = \frac{w - w_p}{I_p}$$

Where w is the natural water content of the soil.

Example – 1

- During a test for water content determination on a soil sample by pycnometer, the following observations were taken
 - (1) Mass of wet soil sample = 1000 gm
 - (2) Mass of pycnometer with soil and filled with water = 2000 gm
 - (3) Mass of pycnometer filled with water only = 1480 gm
 - (4) Specific gravity of solids = 2.67

Determine the water content.

Solution:

$$\begin{aligned} \text{We know that } w &= \left[\left(\frac{M_2 - M_1}{M_3 - M_4} \right) \left(\frac{G - 1}{G} \right) - 1 \right] \times 100 \\ &= \left[\frac{1000}{(2000 - 1480)} \times \left(\frac{2.67 - 1}{2.67} \right) - 1 \right] \times 100 \\ &= 20.28\% \end{aligned}$$

Hence water content of the sample is 20.28%. (Ans)

Example 2:

The mass of an empty gas jar was 0.498 Kg. When completely filled with water its mass was 1.528 Kg. An oven dried sample of soil mass 0.198 Kg was placed in the jar and water was added to fill the jar and its mass was found to be 1.653 Kg. Determine the specific gravity of particle.

Solution: we know that

$$\begin{aligned} G &= \frac{M_2 - M_1}{(M_2 - M_1) - (M_3 - M_4)} \\ &= \frac{0.198}{0.198 - (1.653 - 1.528)} \end{aligned}$$

$$= 2.71$$

Hence specific gravity of the sample is 2.71.

Example 3:

A soil sample consisting of particles of size ranging from 0.5 mm to 0.01 mm, is put on the surface of still water tank 5 metres deep. Calculate the time of settlement of the coarsest and the finest particle of the sample, to the bottom of the tank. Assume average specific gravity of soil particles as 2.66 and viscosity of water as 0.01 poise.

Solution:

$$v = \frac{D^2 \gamma_w (G-1)}{18 \times 10^6 \eta}$$

$$= \frac{D^2 (G-1)}{1.835 \times 10^6 \times \eta}$$

Here $G = 2.66$ and $\eta = 0.01 \times 10^{-4} = 10^{-6} \text{ KN-s/m}^2$

$$v = \frac{D^2}{1.835} \times \frac{2.66-1}{10^6 (10^{-6})}$$

$$= 0.905 D^2$$

Where v is in m/sec and D is in mm

For coarsest particle $D = 0.5 \text{ mm}$

$$v = 0.905(0.5)^2 = 0.2263 \text{ m/sec}$$

$$t = h/v = 5/0.2263 = 22.1 \text{ seconds}$$

for the finest particle, $D = 0.01 \text{ mm}$

$$v = 0.905(0.01)^2 = 9.05 \times 10^{-5} \text{ m/sec}$$

$$t = \frac{5}{9.05 \times 10^{-5}} = 55249 \text{ sec} = 15 \text{ hours } 20 \text{ min } 49 \text{ seconds.}$$

Example 4:

50 grams of oven dried soil sample is taken for sedimentation analysis. The hydrometer reading in a 100 ml soil suspension 30 minutes after the commencement of sedimentation test is 24.5. The effective depth for $R_h = 25$, found from the calibration curve is 10.7 cm. The meniscus correction is found to be +0.5 and the composite correction as $- 2.50$ at the test temperature of 30°C . Taking the specific gravity of particles as 2.75 and viscosity of water as 0.008 poise, calculate the smallest particle size which would have settled during this interval of 30 minutes and the percentage of particles finer than this size.

Solution:

$$R_h' = 24.5$$

$$R_h = 24.5 + 0.5 = 25$$

$$R = 24.5 - 2.5 = 22$$

$$D = \sqrt{\frac{3000\eta}{(G-1)\gamma_w}} \sqrt{\frac{H_e}{t}}$$

Where D is in mm, H_e is in cm and t is in minute.

$$\text{Here } \eta = 0.008 \times 10^{-4} \text{ KN-s/m}^2$$

$$H_e = 10.7 \text{ cm}$$

$$G = 2.75 \text{ and } \gamma_w = 9.81 \text{ KN/m}^3$$

$$t = 30 \text{ min.}$$

$$D = \sqrt{\frac{3000 \times 0.008 \times 10^{-4}}{(2.75-1)9.81}} \times \sqrt{\frac{10.7}{30}}$$

$$= 7.06 \times 10^{-3} \text{ mm}$$

$$= 0.00706 \text{ mm}$$

The percentage finer is given by

$$N' = \frac{100GR}{1} \text{ Md}(G-$$

Where $M_d = \text{mass of dry soil} = 50 \text{ gm}$

$$N' = \frac{100 \times 2.75}{50(2.75-1)} \times 22$$

$$= 69.1 \%$$

(Ans)

Example 5:

A soil has a liquid limit of 25 % and plastic limit is 15 %. Determine the plasticity index. If the water content of the soil in its natural condition in the field is 20 %, find the liquidity index and relative consistency.

Solution:

$$w_l = 25 \%$$

$$w_p = 15 \%$$

$$w = 20 \%$$

$$\text{plasticity Index } I_p = w_l - w_p$$

$$= 25 - 15 = 10 \%$$

$$\text{Liquidity index} = I_l = \frac{w - w_p}{I_p} \times 100$$

$$= \frac{0.2-0.15}{0.1} \times 100 = 50 \%$$

$$\text{Relative consistency} = I_c = \frac{w_1-w}{I_p} \times 100$$

$$= \frac{0.25-0.2}{0.1} \times 100 = 50 \%$$

(Ans)

CHAPTER-4

CLASSIFICATION OF SOIL

Purpose of soil classification:

The purpose of soil classification is to arrange various types of soil into specific groups based on physical properties and engineering behavior of the soils with the objective of finding the suitability of soils for different engineering application , such as in the construction of earth dams , highway ,and foundations of building , etc.

For different areas of applications and with the need for simplicity and acceptable terminology, several soil classification systems have been developed over the years, three of which are listed below.

1. Highway research board classification system
2. Unified soil classification system
3. Indian standard soil classification.

Highway Research Board (HRB) classification System:

The Highway Research Board classification system, also known as Revised Public Roads Administration classification system ,is used to find the suitability of a soil , as sub grade material in pavement construction .This classification system is based on both particle size ranges and plasticity characteristic .soil are divided into 7 primary group designated as A-1 , A-2.....A-7 , as shown in table 4.1.

Group A-1, is divided into two sub groups A-1 and A-1 and group A-2 into four sub groups, A-2-4 , A-2-5 ,A-2-6 and A-2-7 .A characteristic group index is used to describe the performance of a soil as sub grade material.

Group index is not used to place a soil in a particular group ; it is actually a means of rating the value of soil as a sub grade material within its own group .The higher the value of the group index, the proper is the quality of the material.

The group index of a soil depends upon.

- (i) Amount of material passing the 75-micron sieve,
- (ii) Liquid limit
- (iii) Plastic limit

Group index is given by the following equation:

$$\text{Group index} = 0.2a + 0.005ac + 0.01bd$$

Where

a=that portion of percentage passing 75 micron sieve greater than 35 and not exceeding 75 expressed as whole number(0 to 40)

b=that portion percentage passing 75 micron sieve greater than 15 and not exceeding 55 expressed as whole number(0 to 40)

c=that portion of the numerical liquid limit greater than 40 and not exceeded 60 expressed as a positive whole number (0 to 20)

d=that portion of the numerical plasticity index greater than 10 and not exceeding 30 expressed as a positive whole number (0 to 20).

To classify a given soil, sieve analysis data, liquid limit and plasticity index are obtained and we proceed from left to right in the Table 4.1 and by Process of elimination find the first group from into which the test data will fit. This gives the correct Classification. The plasticity index of A-7-5 subgroup is equal to or less than liquid limit minus 30. The plasticity index of A-7-6 subgroup is greater than liquid limit minus 30.

Note: The PRA system was introduced in 1928 and revised in 1945 as HRB system. It is known as AASHTO system since 1978 after adoption by American Association of State Highway and Transportation Officials.

Unified soil classification System

The Unified soil classification system is based on the Airfield Classification system that was developed by A Casagrande .the system based on both grain size and plasticity characteristic of soil. The unified Soil classification (USC)system was adopted jointly by the Corps of Engineers ,U.S. army and U.S. Bureau of Reclamation during 1950s.

1. Coarse-grained soils – if more than 50% by Weighty is retained on No. 200 ASTM sieve.
2. Fine –grain soil- if more than 50% by weight passes through No. 200 ASTM sieve
3. Organic soils.

The soil component are assigned group symbols as indicated below :

Coarse –grained soils:

Gravel: G

Sand: S

Fine grained soils:

Silt: M

Clay's

Organic soil's

Table 4.3 Unified Soil Classification System

Major Division		Group Symbols		Typical names	
<p>Coarse Grain Soils more than 50% retained on No. 200 sieve *</p> <p>Fine grained soils 50% or more passes No. 200 sieve*</p>	<p>Gravels 50% or more of coarse fraction retained on No. 4 sieves</p>	Clear gravels -200 fraction <5%	GW	Well graded	
		Gravel with fine -200 >5% fraction	GP		
		Clean sands -200 <5% fraction	GM		
		Sand with fines - 200 >12% fraction	GC		
	<p>Sand more than 50% of cross fraction passes No. 4 sieve</p>	<p>Sand with fines - 200 >12% fraction</p>	SW		Well graded
			SP		
			SM		
			SC		
<p>Fine-grained soils 50% or more passes No. 200 sieve.</p>					

Table 4.3 gives the details of Unified soil Classification system. The original casagrande plasticity chart used for classifying fine graind soil is given in Fig 4.3

They symbol M for sily in drived from the swedish word 'mo' for silt.

Example4.3. classify the soil with composition indicated in 4.2using USC system .

Solution : Since more than 50% of soil passes through 0.074 mm sieve the soil is fine grained.

Plasticity index = $(50-40)\% = 10\%$

From fig 4.3

For $w_L=40\%$ AND $I_p = 10\%$ the soil can be classified as ML OR OL

INDIAN STANDARD SOIL CLASSIFICATION SYSTEM

Indian standard soil classification system (IS 1498-1970 classification and identification of soil for general engineering purpose) is essentially based on unified soil classification system and the salient features and given in the following discussion.

In the system soils are broadly divided into 3 division

1. coarse- grained soil –if more than 50% by mass is retain on 75 micron IS sieve.
2. Fine grained soil –if more than 50% by mass passes through 75 micron IS sieve.
3. Highly organic soils and other miscelliouns soil material . The soil content larger % of fibrous organic matter such as peat and particles of decompose vegetation. In addition shorten soil containing shells ,concretions cinders and other non soil material insufficient quantities are also grouped in this division.

Coarse grained soils are grouped as gravels and sands with group symbols G and S

Gravels(G) if more than 50% by mass of the coarse grained fraction passed through 4.75 mm IS sieve .

Depending on the gradation gravels(G) and sands (S) are further described using group symbols are indicated below.

GW- Well graded gravel for which $C_u > 4$ and C_c lies between 1&3

GP- poorly graded gravel which does not meet all gradation requirement of GW

SW-Well graded sand for which $C_u > 6$ and C_c lies between 1 & 3

GM-silty gravel if $I_p > 4$ for fine- grained fraction.

GC-Clayey gravel if $I_p < 7$ for fine-grained fraction.

SM-Silty sand if $I_p < 4$ for fine grained fraction.

SC- Clayey sand if $I_p > 7$ for fine- grained fraction.

In the case of coarse –grained soils mixed with fines if I_p lies between 4 and 7 one has to use proper judgment in dealing with this border line case. Generally non-plastic classification is favored in such cases. For example a sand with 10% fines with $C_u > 6$, C_c between 1 and 3 and $I_p = 6$ would be classified as SW –SM rather than SW-SC.

Fine-grained soils are grouped under following three subdivisions with respective group symbols:

Inorganic silts and very fine sands(M)

Inorganic clays(C)

Organic silts ,Organic clays and Organic matter (O)

Depending on liquid limit which is considered a good index of compressibility fine grained soils are described as possessing (i)low compressibility (L) when liquid limit is less than 35 percent .

(ii) intermediate or medium compressibility (I) when liquid limit lies between 35 percent and 50 percent

(iii) high compressibility (H) when liquid limit is greater than 50 percent.

The plasticity chart originally devised by A. Casagrande and slightly modified by IS is used to classify fine-grained soils in the laboratory.

The A-line having the equation:

$$I_p = 0.73 (W_L - 20)$$

And the two vertical lines at $w_L = 35$ and $w_L = 50$ divide the chart into six regions with group symbols marked as shown in Fig.4.4 if the plotted position lies below A-line, the soil has to be checked for organic odour by slight heating. If no organic odour is smelt than only it should be classified as inorganic silt. In case of doubt, the soil should be oven-dried and its liquid limit determined

again. In the case of organic soils there will be large reduction in liquid limit on drying (reduction generally >25%).

Soil	Soil component	Symbol	Particle size range and description
Coarse-grained Components	Boulder	none	Round to angular , bulky hard ,rock particle , average diameter more than 300mm.
	Cobble	None	Round to angular, bulky hard, rock particle average diameter smaller than 300 mm but retained on 80 mm sieve.
	Gravel	G	Rounded to angular, bulky hard, rock particle, passing 80 mm sieve but retained on 4.75 mm sieve. Coarse:80 mm to 20 mm sieve Fine:20 mm to 4.75 mm sieve
	Sand	S	Rounded to angular bulky hard, rocky particle, passing 4.75 mm sieve retained on 75 micron sieve Coarse:4.75 mm to 2.0 mm sieve Medium:2.0 mm to 425 micron sieve Fine: 425 micron to 75 micron sieve
	silt	M	Particles smaller than 75-micron sieve indentified by behavior; that is slightly plastic or non-plastic regardless of moisture and exhibits little or no strength when air

Fine –grained Components			dried
	Clay	C	Particles smaller than 75- micron sieve identified by behavior, than is, it can made to exhibit plastic properties within a certain range of moisture and exhibits considerable strength when air dried

CHAPTER -5

PERMEABILITY AND SEEPAGE

5.1 Concept of Permeability:-

- The property of soil which permits flow of water (or other any liquid) through it is called the permeability in otherworld, the permeability in the case with which water can flow through it.
- Permeability is very important engineering property of soil.
- The knowledge of permeability is essential in a number of soil engineering problems such as: Settlement of Buildings, Yield of wells, Seepage through and below the earth surface.
- Permeability controls the hydraulic stability of soil masses.
- The permeability of soils is also required in the design of filters required to prevent piping in hydraulic structure.

Darcy's Law:-

The flow of free water through soil is governed by Darcy's law. In 1856, Darcy experimentally that for laminar flow in a homogeneous soil, the velocity of flow (v) is given by

$$v = k i \quad \text{--- Equation no -1}$$

Where, k = coefficient of permeability, i = hydraulic gradient and v = velocity of flow in laminar flow in homogeneous soil

The above equation is known as Darcy's law, which is one of the corner stones of soil engineering. The discharge ' q ' is obtained by multiplying the velocity of flow (v) by the total cross-sectional area (A) normal to the direction of flow

$$\text{Thus, } q = vA = k i A \quad \text{--- Equation no -2}$$

Note: - 1) The velocity of flow is also known as discharge velocity or superficial velocity.

2) The area A in the above equation includes both the solids and the voids.

Co-efficient of Permeability:-

- The coefficient of permeability can be defined using the equation 1. If the hydraulic gradient is unity, the coefficient of permeability is equal to the velocity of flow

Or,

- The coefficient of permeability is defined as the velocity of flow which would occur under unit hydraulic gradient. The co-efficient of permeability is equal to the velocity of flow.
- The coefficient permeability has the dimensions of velocity [L/T].
- The coefficient of permeability measured in mm/sec, cm/sec, m/sec, m/day or other velocity units.
- The coefficient of permeability depends upon the particle size and upon many factors.
- According to USBR, the soil having co-efficient permeability greater than 10^{-3} mm/sec are classified as pervious and those with a value less than 10^{-5} to 10^{-3} mm/sec are designated as semi-pervious.

5.2 Factors affecting Permeability of soils:-

The following factors affect the permeability of soils.

- (1) Particle Size.
- (2) Structure of soil mass.
- (3) Shape of particles.
- (4) Void ratio.
- (5) Properties of water.
- (6) Degree of saturation.
- (7) Adsorbed water.
- (8) Impurities in water.

(1) Particle Size: - Co-efficient of permeability of soil is proportional to the square of particle size (D). The permeability of coarse grained soils is very large as compared to that of fine-grained soils. The permeability of coarse sand may be more than one million times as much that of clay.

(2) Structure of soil mass: - The coefficient C takes into account the shape of flow passage. The size of flow passage depends upon the structural arrangement. For same void ratio, the permeability is more in the case of flocculated structure as compared to that in the disperses structure.

Stratified soil deposits have greater permeability parallel to the plane of stratification than that perpendicular to this plane. Permeability of soil deposit also depends upon shrinkage cracks, joints, fissures and shear zones. Loess deposits have greater permeability in the vertical direction than in the horizontal direction.

The permeability of natural soil deposit should be determined in undisturbed condition. The disturbance caused during sampling may destroy the original structure and affect the permeability. The effect of disturbance is more pronounces in case of fine-grained soils than in the case of coarse-grained soils.

(3) Shape of Particles: - The permeability of a soil depends upon the shape of particles. Angular particles have greater specific surface are as compared with the

rounded particles. For the same void ratio, the soils with angular particles are less permeable than those with rounded particles, as the permeability is inversely proportional to the specific surface. However, in a natural deposit, the void ratio for a soil with angular particles may be greater than that for rounded particles, and the soil with angular particles may be actually more permeable.

(4) **Void Ratio:** - For a given soil, the greater the void ratio, the higher is the value of the coefficient of permeability.

Based on the other concepts, it has been established that the permeability of soil varies as e^2 OR $e^2 / (1+e)$ (figure-2). Whatever may be the exact relationship; all soils have e versus $\log k$ plot as a straight line (figure-1).

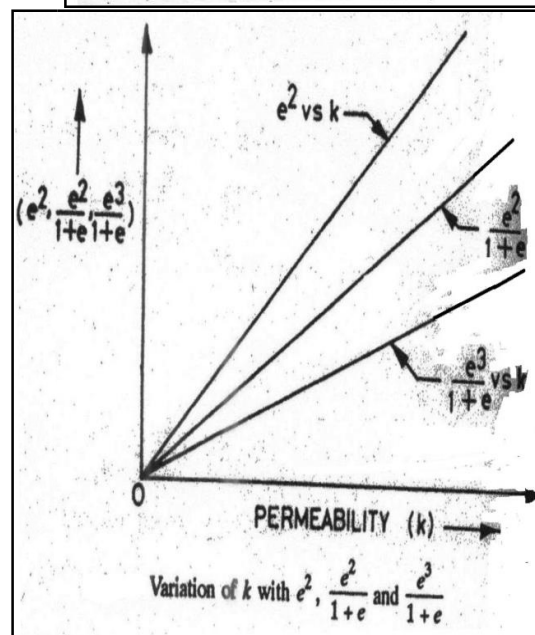
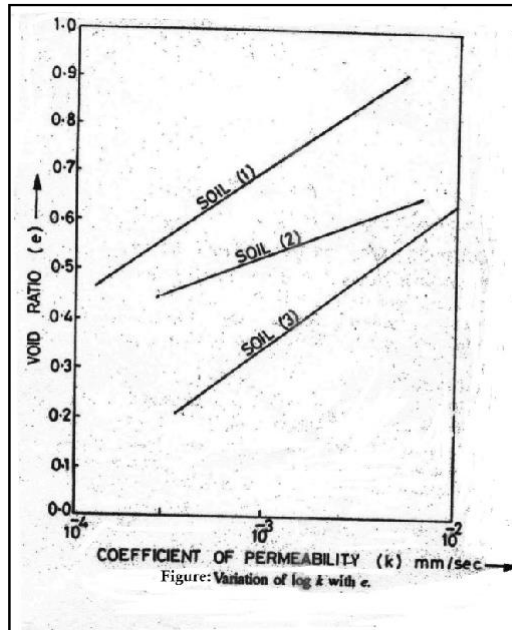

Figure (1)

Figure (2)

If the permeability of a soil at a void ratio of 0.85 is known, its value at another void ratio of 'e' can be determined using the following equation given by Casagrande:

$$k = 1.4 k_{0.85} e^2$$

Where $k_{0.85}$ = permeability at void ratio of 0.85, k = permeability at a void ratio of 'e'.

(5) Properties of Water: - The co-efficient of permeability is directly proportional to the unit weight of water (γ_w) and is inversely proportional to its viscosity (μ). The coefficient of permeability increases with an increase in the temperature due to reduction in the viscosity.

(6) Degree of Saturation: - If the soil is not fully saturated, it contains air pockets formed due to entrapped air or due to air liberated from percolating water. Whatever may be the cause of presence of air in soils, the permeability is reduced due to presence of air which causes blockage of passage. Consequently, the permeability of partially saturated soil is considerably smaller than that of fully saturated soil. In fact Darcy's Law is not strictly applicable to such soils.

(7) Adsorbed Water: - The fine grained soils have a layer of adsorbed water strongly attached to their surface. This adsorbed water layer is not free to move under gravity. It causes an obstruction to flow of water in the pores and hence reduces the permeability of soils.

It is difficult to estimate the void occupied by the adsorbed water. According to one estimate, the void ratio occupied by adsorbed water is about 0.10. The effective void ratio available for flow of water is thus about $(e - 0.1)$ and not 'e'. In some cases, at very low hydraulic gradient, the coefficient of permeability of fine-grained soils becomes negligible small due to presence of adsorbed water.

(8) Impurities in Water: - Any foreign matter in water has a tendency to plug the flow passage and reduce the effective voids and hence the permeability of soils.

5.3.1 - Constant Head Permeability Test:-

The coefficient of permeability of a relatively more permeable soil can be determined in a laboratory by the constant-head permeability test.

1. The test is conducted in an instrument known as constant-head Permeameter.
2. It consists of a metallic mould, 100 mm internal diameter, 127.3 mm effective height and 1000 ml capacity according to IS : 2720 (Part XVII).
3. The mould is provided with a detachable extension collar, 100 mm diameter and 60 mm high, required during compaction of soil.
4. The mould is provided with drainage base plate with recess for porous stone.
5. The mould is fitted with a drainage cap having an inlet valve and an air release valve.
6. The drainage base and cap have fittings for clamping to the mould.

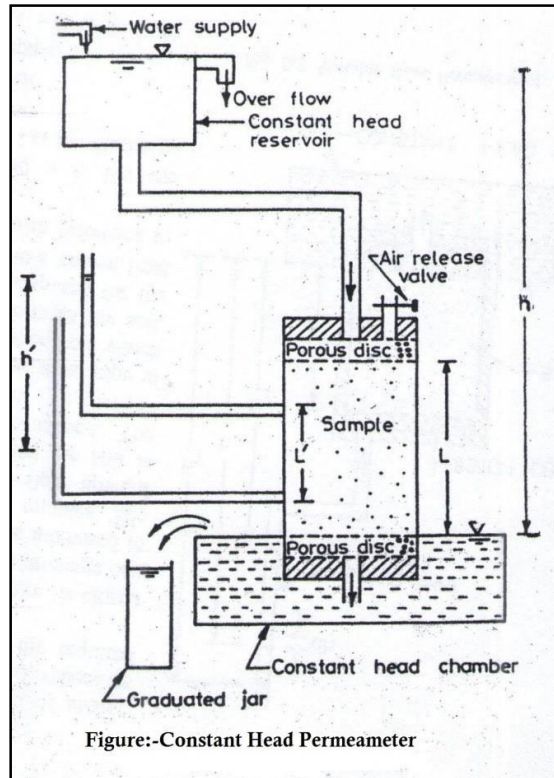

1. The above figure shows a schematic sketch.
2. The soil sample is placed inside the mould between two porous discs.
3. The porous discs should be at least ten times more permeable than the soil.
4. The porous discs should be deaired before these are placed in the mould.
5. The water tubes should also be deaired.
6. The sample can also be prepared in the permeameter by pouring the soil into it and tamping it to obtain the required density.
7. The base is provided with a dummy plate, 12 mm thick and 108 mm in diameter, which is used when the sample is compacted in the mould.
8. It is essential that the sample is fully saturated. This is done by one of the following three methods:-
 - i. By pouring the soil in the permeamter filled with water and thus depositing the soil under water.
 - ii. By allowing water to flow from the base to the top after the soil has been placed in the mould. This is done by attaching the constant-head reservoir to the drainage base. The upward flow is maintained for sufficient time till all the air has been expelled out.
 - iii. By applying a vacuum pressure of about 700mm of mercury through the drainage cap for about 1.5 minutes after closing the drainage valve. Then the soil is saturated by allowing deaired water to enter from drainage base. The air-release valve is kept open during saturation process.
9. After the soil sample has been saturated, the constant-head reservoir is connected to the drainage cap.
10. Water is allowed to flow out from the drainage base for some time till a steady-state is established.

11. The water level in the constant-head chamber in which the mould is placed is kept constant.
12. The chamber is filled to the brim at the start of the experiment.
13. The water which enters the chamber after flowing through the sample spills over the chamber and collected in a graduated jar for convenient period.
14. The head causing flow (h) is equal to the difference in water levels between the constant-head reservoir and the constant-head chamber.
15. If the cross-sectional area of the specimen is A, the discharge is given by

$$q = k i A$$

$$\text{or, } q = k (h/l) A$$

$$\text{or, } k = (q l) / (A h)$$

where, L= Length of specimen, h= head causing flow.

The discharge q is equal to the volume of water collected divided by time. The finer particles of soil specimen have a tendency to migrate towards the end faces when water flows through it. This results in the formation of a filter skin at the ends. The coefficient of permeability of these end portions is quite different from that of middle portion. For more accurate results, it would be preferable to measure the loss of head h' over a length L' in the middle to determine the hydraulic gradient (i). Thus $i = h' / L'$.

The temperature of permeating water should be preferably somewhat higher than that of the soil sample. This will prevent release of air during the test. It also helps in removing the entrapped air in the pores of soil. As the water cools, it has tendency to absorb air.

To reduce the chances of formation of large voids at the points where the particles of soil touch the permeameter walls, the diameter of the permeameter is kept at least 15 to 20 times the particles size.

To increase the rate of flow for the soils of low permeability, a gas under pressure is applied to the surface of water in the constant-head reservoir. The total head causing flow in that case increase to $(h + p / \gamma_w)$, where p is pressure applied.

The bulk density of the soil in the mould may be determined from the mass of soil in the mould and its volume. The bulk density should be equal to that in the field. The undisturbed sample can also be used instead of the compacted sample. For accurate results, the specimen should have the same structure as in natural conditions.

The constant head permeability test is suitable for clean sand and gravel with $k > 10^{-2}$ mm/sec.

5.3.2- Falling Head / Variable Head Permeability Test:-

For relatively less permeability soils the quantity of water collected in the graduated jar of the constant-head permeability test is very small and cannot be accurately. For such soils, the variable-head permeability test is used. The permeameter mould is the same as used in the constant-head permeability test.

- 1) A vertical, graduated stand pipe of known diameter is fitted to the top of permeameter.

- 2) The sample is placed between two porous discs.
- 3) The whole assembly is placed in a constant head chamber filled with water to brim at the start of the test. (See the below figure shows a schematic sketch).

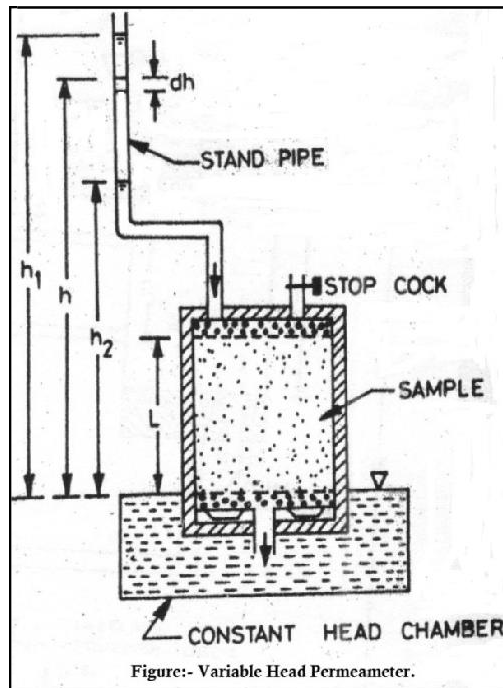

- 4) Tee porous discs and water tubes be de-aired before the sample is placed. If in-situ, undisturbed sample is available, the same can be used; otherwise the soil is taken in the mould and compacted to required density.
- 5) The valve at the drainage base (not shown in figure) is closed and vacuum pressure is applied slowly through the drainage cap to remove air from the soil.
- 6) The vacuum pressure is increased to 700 mm of mercury and maintained for about 15 minutes.
- 7) The sample is saturated by allowing deaired water to flow upward from the drainage base when under vacuum.
- 8) When the soil is saturated, both the top and bottom outlets are closed.
- 9) The standpipe is filled with water to required height.
- 10) The test is stated by allowing the water in the stand pipe to flo through the sample to constant-head chamber from which it overflows and spills out.
- 11) As the water flows through the soil, the water level in the standpipe falls.
- 12) The time required for the water level to fall from a known initial head (h_1) to known as final head (h_2) is determined.
- 13) The head is measured with reference to the level of water in the constant-head chamber.

Let us consider the instant when the head is h . For the infinitesimal small time dt , the head falls by dh .

Let the discharge through the sample be q .

From continuity of flow, $a dh = - q dt$

Where 'a' is cross-sectional area of standpipe.

$$\text{Or, } a dh = - (A \times k \times i) \times dt$$

$$\text{Or, } a dh = - A \times k \times h/L \times dt$$

$$\text{Or, } A k dt / a L = -dh / h$$

$$\text{Integrating, } \frac{A k}{a L} \int_{t_1}^{t_2} dt = - \int_{h_1}^{h_2} \frac{dh}{h}$$

$$\frac{A k}{a L} (t_2 - t_1) = \log_e (h_1/h_2)$$

$$k = \frac{A k}{a L} \log_e (h_1/h_2)$$

Where, $t = (t_2 - t_1)$, the time interval during which the head reduces from h_1 to h_2).

$$\text{Sometime } k = \frac{2.30 a L}{A t} \log_{10} (h_1/h_2)$$

The rate of fall of water level in the stand pipe and the rate of flow can be adjusted by changing the area of cross-section of the standpipe. The smaller diameter pipes are required for less pervious soils.

The coefficient of permeability is reported at 27° C as per IS : 2720 (Part XVII). The void ratio soil is also generally determined.

The variable head permeameter is suitable for very fine sand and silt with $k = 10^{-2}$ to 10^{-5} mm/sec.

Sometime, the permeability test is conducted using the consolidometer instead of the permeameter mould. The fixed-ring consolidometer is used a variable head permeameter by attaching a stand.

5.4.1 - Seepage Pressure:-

As water flows through the soil, it exerts a force on the soil. The force acts in the direction of flows. This force is known as drag force or seepage force. The pressure induced in the soil is known as seepage pressure.

Or

By virtue of the viscous friction exerted on water flowing through soil energy transfer is effected between the water and soil. The force corresponding to this energy transfer is called the seepage force or seepage pressure. Thus, seepage pressure is the pressure exerted by water on the soil through which percolates.

5.4.2 - The phenomenon of Quick Sand:-

When flow takes place in an upward direction, the seepage pressure also acts in the upward direction and the effective pressure is reduced. If the seepage pressure becomes equal to the pressure due to submerged weight of the soil, the effective pressure is reduced to zero, in such case, a cohesionless soil loses all its shear strength, and the soil particles have a tendency to move up in the direction of flow. This phenomenon of lifting of soil particles is called *quick condition*, boiling condition or quick sand. Thus, during the quick condition,

$$\sigma' = z\gamma' - p_s = 0$$

or, $p_s = z\gamma'$

or $iz\gamma_w = z\gamma'$

From which,

$$I = i_c = \gamma' / \gamma_w = \frac{G-1}{1+e}$$

- The hydraulic gradient at such a critical state is called hydraulic gradient. For loose deposits of sand or sand or silt, if voids ratio e is taken as 0.67 and G as 2.67, the critical hydraulic gradient works out to be unity.
- It should be noted that quick sand is not a type of sand but a flow condition occurring within a cohesionless soil when its effective pressure is reduced to zero due to upward flow of water.

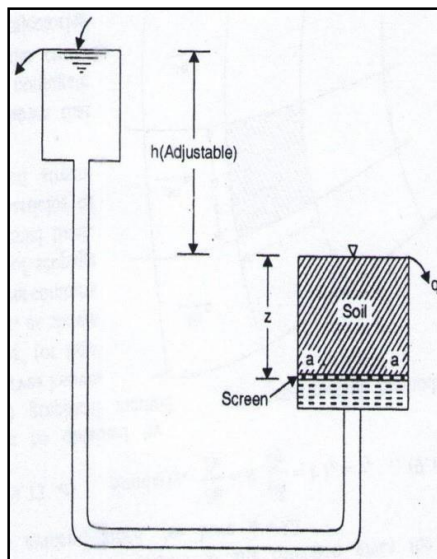

Figure: - QUICK SAND CONDITION

1. The figure shows a set-up to demonstrate the phenomenon of quick sand.
2. Water flows in an upward direction through a saturated soil sample of thickness ' z ' under a hydraulic head ' h '.
3. This head can be increased or decreased by moving the supply tank in the upward or downward direction.
4. When the soil particles are in the state of critical equilibrium, the total upward force at the bottom of soil becomes equal to the total weight of all the materials above the surface considered.

Equating the upward and downward forces at the level $a-a$, we have,

$$(h + z) \gamma_w A = z\gamma_{sat} A$$

$$h\gamma_w = z(\gamma_{sat} - \gamma_w) = z\gamma'$$

$$\frac{h}{z} = i_c = \gamma' / \gamma_w = \frac{G-1}{1+e}$$

5.5.1- Concept of Flow-Net:-

1. The graphical method of flow net construction, first given by Forchheimer (1930), is based on trial sketching.
2. The hydraulic boundary conditions have a great effect on the general shape of the flow net, and hence must be examined before sketching is started.
3. The flow net can be plotted by trial and error by observing the properties of flow net and by following practical suggestion given by A.Casagrande.

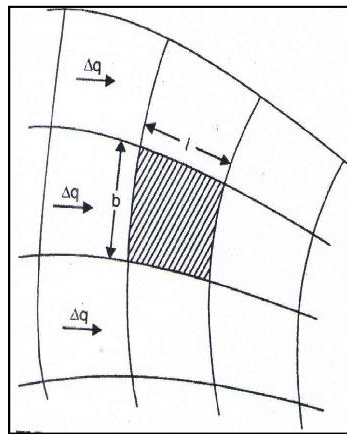

Figure: - PORTION OF A FLOW NET

5.5.2- Properties of Flow-Net:-

1. The flow lines and equipotential line meet at right angles to one another.
2. The fields are approximately squares, so that a circle can be drawn touching all the four sides of the square.
3. The quantity of water flowing through each flow channel is same, similarly, the same potential drop occurs between two successive equipotential lines
4. Smaller the dimensions of the field, greater will be the hydraulic gradient and velocity through it.
5. In a homogeneous soil, every transition in the shape of the curves is smooth, being either elliptical in shape.

5.5.3- Application of Flow-Net:-

A flow net can be utilized for the following purposes:-

- a) Determination of seepage.
- b) Determination of hydrostatic pressure.
- c) Determination of seepage pressure.

d) Determination of exist gradient.

(a) Determination of seepage:- Figure shows a portion of flow net. The portion between any two successive flow lines is known as flow channel. The portion enclosed between two successive equipotential lines and successive flow lines is known as field as that shown hatched in the figure

Let b & l be the width and length of the field

Δh = head drop through the field

Δq = Discharge passing through the flow channel

H = total hydraulic head causing flow = difference between upstream and downstream heads.

$$b = k H (N_f / N_d),$$

Where, N_f = Total number of flow channel in the net

N_d = Total number of potential drops in the complete net

This is required expression for the discharge passing through a flow-net and valid for isotropic soils in which $k_x = k_y = k$.

(b) Determination of hydrostatic pressure:- The hydrostatic pressure at any point within the soil mass is given by $u = \gamma_w h_w$

Where u = hydrostatic pressure, h_w = Pizometric head

The hydrostatic pressure in terms of Pizometric head h_w is calculated from the relation -

$$h_w = h - Z$$

Where h = Hydraulic potential at the point under consideration.

Z = position head of the point above datum, considered positive upwards.

(c) Determination of seepage pressure:- The hydraulic potential h at any point located after n potential drops, each value Δh is given by

$$h = H - n \Delta h$$

the seepage pressure at any point equals the hydraulic potential or balanced hydraulic head multiplied by unit weight of water and hence is given by $p_s = h \gamma_w = (H - n \Delta h) \gamma_w$

The pressure acts in the direction of flow.

(d) Determination of exist gradient:- The exit gradient is hydraulic at the downstream end of the flow line where the percolating water leaves the soil mass and emerges into the free water at the downstream. The exit gradient can be calculated from the following expression, in which Δh represents the potential drop and l the average length of last field in the flow net at exit end:

$$i_e = (\Delta h / l).$$

CHAPTER- 6

COMPACTION AND CONSOLIDATION

6.1 COMPACTION

Compaction is the application of mechanical energy to a soil so as to rearrange its particles and reduce the void ratio.

It is applied to improve the properties of an existing soil or in the process of placing fill such as in the construction of embankments, road bases, runways, earth dams, and reinforced earth walls. Compaction is also used to prepare a level surface during construction of buildings. There is usually no change in the water content and in the size of the individual soil particles.

The objectives of compaction are:

- To increase soil shear strength and therefore its bearing capacity.
- To reduce subsequent settlement under working loads.
- To reduce soil permeability making it more difficult for water to flow through.

LIGHT AND HEAVY COMPACTION TEST

Laboratory Compaction

The variation in compaction with water content and compactive effort is first determined in the laboratory. There are several tests with standard procedures such as:

- Indian Standard Light Compaction Test (similar to Standard Proctor Test)
- Indian Standard Heavy Compaction Test (similar to Modified Proctor Test)

Indian Standard Light Compaction Test

Soil is compacted into a 1000 cm³ mould in 3 equal layers, each layer receiving 25 blows of a 2.6 kg rammer dropped from a height of 310 mm above the soil. The compaction is repeated at various moisture contents.

Indian Standard Heavy Compaction Test

It was found that the Light Compaction Test (Standard Test) could not reproduce the densities measured in the field under heavier loading conditions, and this led to the development of the Heavy Compaction Test (Modified Test). The equipment and procedure are essentially the same as that used for the Standard Test except that the soil is compacted in 5 layers, each layer also receiving 25 blows. The same mould is also used. To provide the increased compactive effort, a heavier rammer of 4.9 kg and a greater drop height of 450 mm are used.

OPTIMUM MOISTURE CONTENT OF SOIL, MAXIMUM DRY DENSITY, ZERO AIR VOID LINE

To assess the degree of compaction, it is necessary to use the dry unit weight, which is an indicator of compactness of solid soil particles in a given volume. The laboratory testing is meant to establish the maximum dry density that can be attained for a given soil with a standard amount of compactive effort.

In the test, the dry density cannot be determined directly, and as such the bulk density

and the moisture content are obtained first to calculate the dry density as $\gamma_d = \frac{\gamma_t}{1+w}$, where γ_t = bulk density, and w = water content.

A series of samples of the soil are compacted at different water contents, and a curve is drawn with axes of dry density and water content. The resulting plot usually has a distinct peak as shown. Such inverted “V” curves are obtained for **cohesive soils** (or soils with fines), and are known as compaction curves.

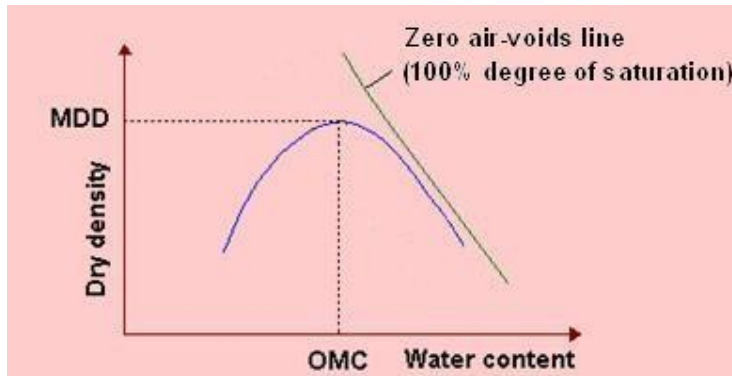

Dry density can be related to water content and degree of saturation (S) as

$$\gamma_d = \frac{G_s \cdot \gamma_w}{1+e} = \frac{G_s \cdot \gamma_w}{1 + \frac{w \cdot G_s}{S}}$$

Thus, it can be visualized that an increase of dry density means a decrease of voids ratio and a more compact soil.

Similarly, dry density can be related to percentage air voids (n_a) as

$$\gamma_d = \frac{(1-n_a)G_s \cdot \gamma_w}{1+wG_s}$$

The relation between moisture content and dry unit weight for a saturated soil is the **zero air-voids line**. It is not feasible to expel air completely by compaction, no matter how much compactive effort is used and in whatever manner.

Effect of Increasing Water Content

As water is added to a soil at low moisture contents, it becomes easier for the particles to move past one another during the application of compacting force. The particles come closer, the voids are reduced and this causes the dry density to increase. As the water content increases, the soil particles develop larger water films around them.

This increase in dry density continues till a stage is reached where water starts occupying the space that could have been occupied by the soil grains. Thus the water at this stage hinders the closer packing of grains and reduces the dry unit weight. The **maximum dry density (MDD)** occurs at an **optimum water content (OMC)**, and their values can be obtained from the plot.

Effect of Increasing Compactive Effort

The effect of increasing compactive effort is shown. Different curves are obtained for different compactive efforts. A greater compactive effort reduces the optimum moisture content and increases the maximum dry density.

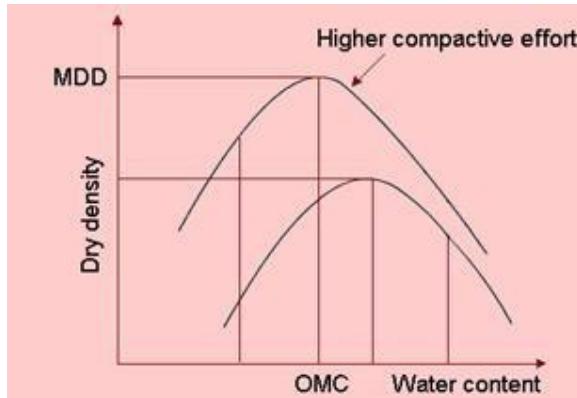

An increase in compactive effort produces a very large increase in dry density for soil when it is compacted at water contents drier than the optimum moisture content. It should be noted that for moisture contents greater than the optimum, the use of heavier compaction effort will have only a small effect on increasing dry unit weights.

It can be seen that the compaction curve is not a unique soil characteristic. It depends on the compaction effort. For this reason, it is important to specify the compaction procedure (light or heavy) when giving values of MDD and OMC.

6.2 Factors Affecting Compaction

The factors that influence the achieved degree of compaction in the laboratory are:

- Plasticity of the soil
- Water content
- Compactive effort

6.3 FIELD COMPACTION METHODS AND THEIR SUITABILITY

Compaction Equipment

Most of the compaction in the field is done with rollers. The four most common types of rollers are

1. Smooth-wheel rollers (or smooth-drum rollers)
2. Pneumatic rubber-tired rollers
3. Sheepsfoot rollers
4. Vibratory rollers

Smooth-wheel rollers are suitable for proof rolling subgrades and for finishing operation of fills with sandy and clayey soils. These rollers provide 100% coverage under the wheels, with ground contact pressures as high as 310 to 380 kN/m² (45 to 55 lb/in²). They are not suitable for producing high unit weights of compaction when used on thicker layers.

Pneumatic rubber-tired rollers are better in many respects than the smooth-wheel rollers. The former are heavily loaded with several rows of tires. These tires are closely spaced—four to six in a row. The contact pressure under the tires can range from 600 to 700 kN/m² (85 to 100 lb/in²), and they produce about 70 to 80% coverage. Pneumatic rollers can be used for sandy and clayey soil compaction. Compaction is achieved by a combination of pressure and kneading action.

Sheepsfoot rollers are drums with a large number of projections. The area of each projection may range from 25 to 85 cm² (4 to 13 in²). These rollers are most effective in compacting clayey soils. The contact pressure under the projections can range from 1400 to 7000 kN/m² (200 to 1000 lb/in²). During compaction in the field, the initial passes compact the lower portion of a lift. Compaction at the top and middle of a lift is done at a later stage. Vibratory rollers are extremely efficient in compacting granular soils. Vibrators can be attached to smooth-wheel, pneumatic rubber-tired, or sheepsfoot rollers to provide vibratory effects to the soil.

Handheld vibrating plates can be used for effective compaction of granular soils over a limited area. Vibrating plates are also gang-mounted on machines. These plates can be used in less restricted areas..

6.4 CONSOLIDATION:

According to Terzaghi (1943), “a decrease of water content of a saturated soil without replacement of the water by air is called a process of consolidation.” When saturated clayey soils-which have a low coefficient of permeability-are subjected to a compressive stress due to a foundation loading, the pore water pressure will immediately increase; however, due to the low permeability of the soil, there will be a time lag between the application of load and the extrusion of the pore water and, thus, the settlement.

DIFFERENCE BETWEEN COMPACTION AND CONSOLIDATION:

Consolidation and compaction are totally different process. Though both process results a reduction in volume, it is important to know the difference between them. These are:



a. Compaction reduces volume of soil by rapid mechanical methods like tamping, rolling and vibration; whereas consolidation process reduces volume gradually by static, sustained loading.

b. Compaction decreases volume by expelling air from partially saturated or dry soil; whereas consolidation process reduces volume by squeezing out water from saturated soil. In compaction process water content is not altered.



c. Compaction is a human generated pressing method to produce high unit weight of soil. Thus increasing other properties to have better founding soil. In contrast, consolidation is natural process where volume of saturated soil mass reduced by static loads from the weight of building or other structures that is transferred to soil through a foundation system.

6.5 SPRING ANALOGY METHOD

The process of consolidation is often explained with an idealized system composed of a spring, a container with a hole in its cover, and water. In this system, the spring represents the compressibility or the structure of the soil itself, and the water which fills the container represents the pore water in the soil.

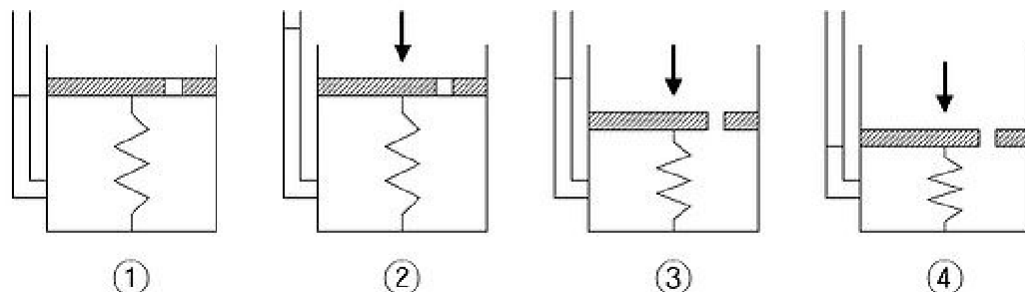

1. The container is completely filled with water, and the hole is closed. (Fully saturated soil)
2. A load is applied onto the cover, while the hole is still unopened. At this stage, only the water resists the applied load. (Development of excess pore water pressure)
3. As soon as the hole is opened, water starts to drain out through the hole and the spring shortens. (Drainage of excess pore water pressure)
4. After some time, the drainage of water no longer occurs. Now, the spring alone resists the applied load. (Full dissipation of excess pore water pressure. End of consolidation)

Pressure-Void Ratio Curve:-

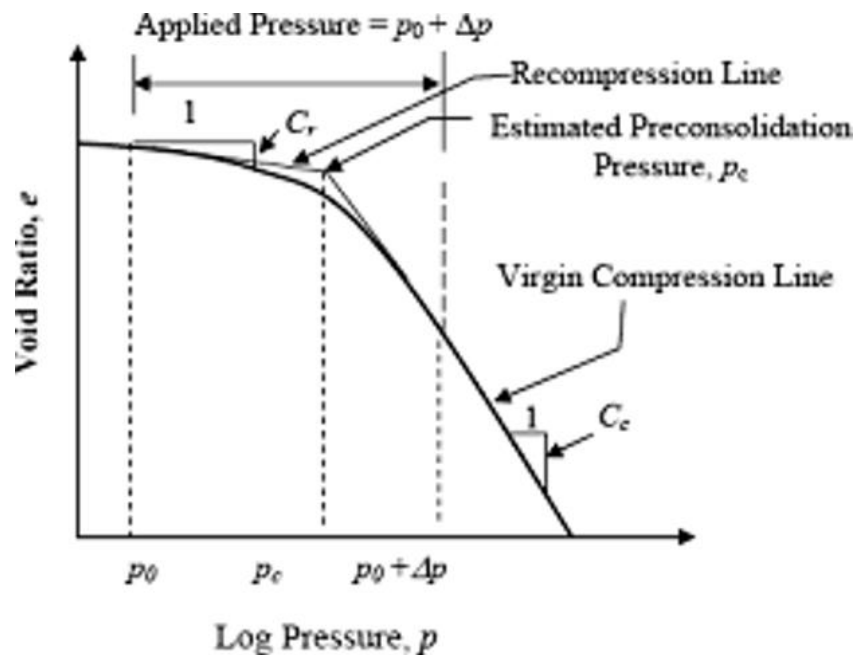

Normally consolidated, Under consolidated and Over consolidated soil,

Consolidation is a process by which soils decrease in volume. According to Karl von Terzaghi "consolidation is any process which involves a decrease in water content of saturated soil without replacement of water by air." In general it is the process in which reduction in volume takes place by expulsion of water under long term static loads. It occurs when stress is applied to a soil that causes the soil particles to pack together more tightly, therefore reducing its bulk volume. When this occurs in a soil

that is saturated with water, water will be squeezed out of the soil. The magnitude of consolidation can be predicted by many different methods. In the Classical Method, developed by Terzaghi, soils are tested with an oedometer test to determine their compression index. This can be used to predict the amount of consolidation.

When stress is removed from a consolidated soil, the soil will rebound, regaining some of the volume it had lost in the consolidation process. If the stress is reapplied, the soil will consolidate again along a recompression curve, defined by the recompression index. The soil which had its load removed is considered to be overconsolidated. This is the case for soils which have previously had glaciers on them. The highest stress that it has been subjected to is termed the preconsolidation stress. The over consolidation ratio or OCR is defined as the highest stress experienced divided by the current stress. A soil which is currently experiencing its highest stress is said to be normally consolidated and to have an OCR of one. A soil could be considered underconsolidated immediately after a new load is applied but before the excess pore water pressure has had time to dissipate.

Assumption of Terzaghi's theory of one-dimensional consolidation

1. The soil is homogenous (uniform in composition throughout).
2. The soil is fully saturated (zero air voids due to water content being so high).
3. The solid particles and water are incompressible.
4. Compression and flow are one-dimensional (vertical axis being the one of interest).
5. Strains in the soil are relatively small.
6. Darcy's Law is valid for all hydraulic gradients.
7. The coefficient of permeability and the coefficient of volume compressibility remain constant throughout the process.
8. There is a unique relationship, independent of time, between the void ratio and effective stress

Coefficient of Consolidation:

The Coefficient of consolidation at each pressures increment is calculated by using the following equations:

i. $C_v = 0.197 d^2/t_{50}$ (Log fitting method)

In the log fitting method, a plot is made between dial readings and logarithmic of time, the time corresponding to 50% consolidation is determined

ii. $C_v = 0.848 d^2/t_{90}$ (Square fitting method)

In the square root fitting method, a plot is made between dial readings and square root of time and the time corresponding to 90% consolidation is determined.

Time Factor:-

The magnitude of consolidation settlement is often calculated using Terzaghi's expression for average degree of consolidation (U) with respect to time. Developed during a time of limited computing capabilities, Terzaghi's series solution to the one-dimensional consolidation equation was generalized using a dimensionless time factor (T), where a single U-T curve is used to describe the consolidation behavior of both singly and doubly drained strata. As a result, any comparisons between one- and two-way drainage are indirect and confined to discrete values of time. By introducing a modified time factor T^ in terms of layer thickness (D) instead of the maximum drainage path length (Hdr), it is now possible to observe the effect of drainage conditions over a continuous range of time for a variety of asymmetric initial excess pore pressure distributions. Although two separate U-T plots are required (for singly and doubly drained cases), the time factor at specific times remains the same for both cases, enabling a direct visual comparison. The importance of a revised time factor is evident when observing the endpoint of consolidation, which occurs as U approaches 100%. This occurs at $T^* \cong 0.5$ for two-way drainage and at $T^* \cong 2$ for one-way drainage, an observation not possible using the traditional expression for time factor.*

Estimation of consolidation settlements

Prediction of ground settlements have always been a big challenge for the engineers that are responsible for the design of subway tunnel projects. Since ground settlement is a crucial concept directly affecting the successfulness of a project, it must be taken seriously and should be accurately estimated.

Categories:

1. Immediate settlement - elastic deformation of dry soil and moist and saturated soils without change to moisture content
 - a. due to high permeability, pore pressure in clays support the entire added load and no immediate settlement occurs
 - b. generally, due to the construction process, immediate settlement is not important
2. Primary consolidation settlement - volume change in saturated cohesive soils because of the expulsion of water from void spaces
 - a. high permeability of sandy, cohesionless soils result in near immediate drainage due to the increase in pore water pressure and no primary consolidation settlement occur

DIFFERENCE BETWEEN PRIMARY AND SECONDARY CONSOLIDATION

Primary consolidation

This method assumes consolidation occurs in only one-dimension. Laboratory data is used to construct a plot of strain or void ratio versus effective stress where the effective stress axis is on a logarithmic scale. The plot's slope is the compression index or recompression index. The equation for consolidation settlement of a normally consolidated soil can then be determined to be:

$$\delta_c = \frac{C_c}{1 + e_0} H \log \left(\frac{\sigma'_{zf}}{\sigma'_{z0}} \right)$$

where

δ_c is the settlement due to consolidation.

C_c is the compression index.

e_0 is the initial void ratio.

H is the height of the soil.

σ'_{zf} is the final vertical stress.

σ'_{z0} is the initial vertical stress.

C_c can be replaced by C_r (the recompression index) for use in overconsolidated soils where the final effective stress is less than the preconsolidation stress. When the final effective stress is greater than the preconsolidation stress, the two equations must be used in combination to model both the recompression portion and the virgin compression portion of the consolidation processes, as follows,

$$\delta_c = \frac{C_r}{1 + e_0} H \log \left(\frac{\sigma'_{zc}}{\sigma'_{z0}} \right) + \frac{C_c}{1 + e_0} H \log \left(\frac{\sigma'_{zf}}{\sigma'_{zc}} \right)$$

where σ_{zc} is the preconsolidation stress of the soil.

Secondary consolidation

Secondary consolidation is the consolidation of soil that takes place after primary consolidation. Even after the reduction of hydrostatic pressure some compression of soil takes place at slow rate. This is known as secondary consolidation. Secondary consolidation is caused by creep, viscous behavior of the clay-water system, consolidation of organic matter, and other processes. In sand, settlement caused by secondary compression is negligible, but in peat, it is very significant. Due to secondary consolidation some of the highly viscous water between the points of contact is forced out.

Secondary consolidation is given by the formula

$$S_s = \frac{H_0}{1 + e_0} C_a \log \left(\frac{t}{t_{90}} \right)$$

Where

H_0 is the height of the consolidating medium

e_0 is the initial void ratio

C_a is the secondary compression index

t is the length of time after consolidation considered

t_{90} is the length of time for achieving 90% consolidation

CHAPTER-7

SHEAR STRENGTH

Introduction

Soil mass when loaded may fail due to shear stress induced in it. Examples of such failures are sinking of soil mass under heavily loaded foundation, spalling of soil along the edge of vertical cut, slide in an earth embankment with a steep slope movement of backfill behind a weak retaining wall etc. In all the above cases, the soil fails essentially due to shear. When the shear stress induced in a mass of soil reaches limiting value, shear deformation occurs, which leads to the failure of soil mass. The resistance offered by the soil to shear is known as shear resistance.

The maximum shearing resistance of soil against continuous shear deformation along potential failure plane is known as **shear strength** of soil. The plane along which failure of soil takes place due to sliding is known as failure plane. Failure will take place on the plane on which the shear stress exceeds the shear resistance. However, if the soil has weak planes, the failure will be located in the weakest zone. Failure may not take place along the plane of maximum shear stress, i.e., the plane which makes 45° with the principal planes.

The shearing resistance of soil is composed of two components: Normal stress dependent and normal stress independent. Examples of the above two cases are:

1. Frictional resistance between the particles at the point of contact
2. Cohesion or force of attraction between soil particles. It is characteristic of soil state and is independent of normal stress across the plane.

The above two components can be better understood by comparing two materials, sand and clay. Considerable force is required to shear a block of clay as shown in the Figure 1(a) even when there is no external force acting on the block. This force is higher when the block is dry and lower with increase in water content of the soil sample. This component is called cohesion. On the other hand, if we take a sample of sand in a split mould and try to shear it, the force required is practically nil when there is no external normal force. Now, if we apply external normal pressure, the force

required to shear the sample increases and is proportional to the normal pressure applied. This component is called friction.

Shear strength of the cohesionless soil results from inter granular friction as above. Plastic undrained clay does not have external friction. Hence, strength of soil results from cohesion alone. In other intermediate soils, shear strength of such soil results from internal friction as well as cohesion.

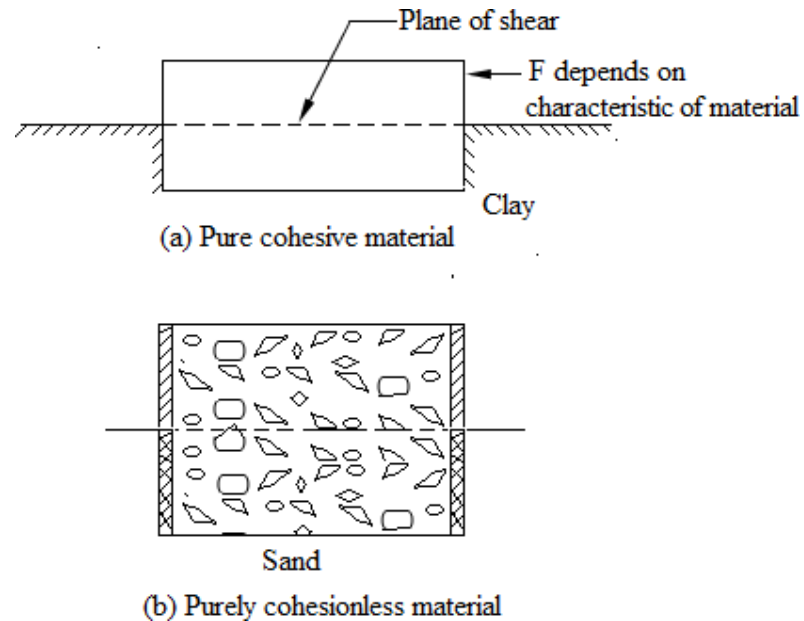

Figure 1

Theory of two dimensional stress system: Mohr's Stress Circle

Innumerable planes pass through each point in a soil mass. The stress components on each plane through the point depend upon the direction of the plane. It is known from strength of material that there exists three mutually perpendicular planes through a point on which there is no shear stress and only normal stress acts. Such planes are called principal planes and the normal stresses, the principal stresses. In order of their magnitude, these stresses are known as major principal stress (σ_1), intermediate principal stress (σ_2) and minor principal stress (σ_3). However, in most soil we deal with, failure of soil mass is independent of intermediate stress. In such problems two dimensional stress analyses gives acceptable results for the solution of such failure problems.

Consider the case of a soil element as in Figure 2 whose sides are principal planes i.e., only normal stresses are acting on the faces of the element. The stress components at a point on a give plane are given by

$$\sigma = \frac{\sigma_1 + \sigma_3}{2} + \frac{\sigma_1 - \sigma_3}{2} \cos 2\alpha$$

$$\tau = \frac{\sigma_1 - \sigma_3}{2} \sin 2\alpha$$

where σ and τ are normal stress and shear stress component on a plane inclined at an angle of α with the major principal plane.

The above results can be represented by drawing a circle with radius $\frac{\sigma_1 - \sigma_3}{2}$. The circle so drawn is known as Mohr's circle. Each point on the circumference of the circle gives two stress coordinates at that point on an inclined plane.

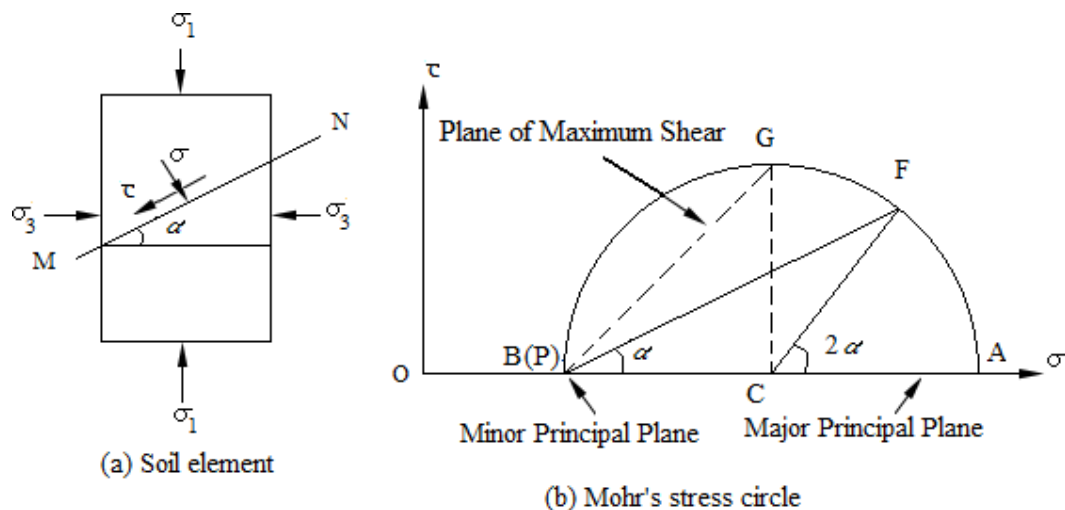

Figure 2 Mohr's stress circle

In Figure 2(a), the major principal plane is horizontal and minor principal plane is vertical. Point A in the Mohr's circle represents the major principal stress $(\sigma_1, 0)$ and B represents the minor principal stress $(\sigma_3, 0)$. To determine the stress components in a plane through the point, a point called pole is to be located on the circle. The pole is drawn by drawing a straight line parallel to the plane on which the stress conditions

are known. Hence, the pole P is located by drawing a horizontal line through the point A representing the major principal stress (σ_1). The pole can also be represented by drawing a vertical line through B representing minor principal plane (σ_3). To know the stress on the inclined plane, a straight line PF parallel to the plane is drawn through the pole P . The point F on the circle gives the coordinates of the stress on the plane inclined at an angle α with the direction of major principal plane. The shear stress is considered to be positive if its direction gives a clockwise moment about a point outside the wedge such as point E .

Consider another soil element as shown in Figure 3(a) in which major principal planes are not horizontal and vertical, but are inclined to y and x -directions. The corresponding Mohr's stress circle is drawn as shown in Figure 3(b). Point A represents principal major principal stress ($\sigma_1, 0$) and minor principal stress ($\sigma_3, 0$). To locate the pole, a line parallel to the major principal plane is drawn through A to intersect the circle at P . PB gives the direction of the minor principal plane. To determine the stress components on any plane MN inclined at an angle α with the major principal plane, a line making an angle of α with PA is drawn through P , to intersect the circle at F . The coordinates of point F give the stress components on the plane MN .

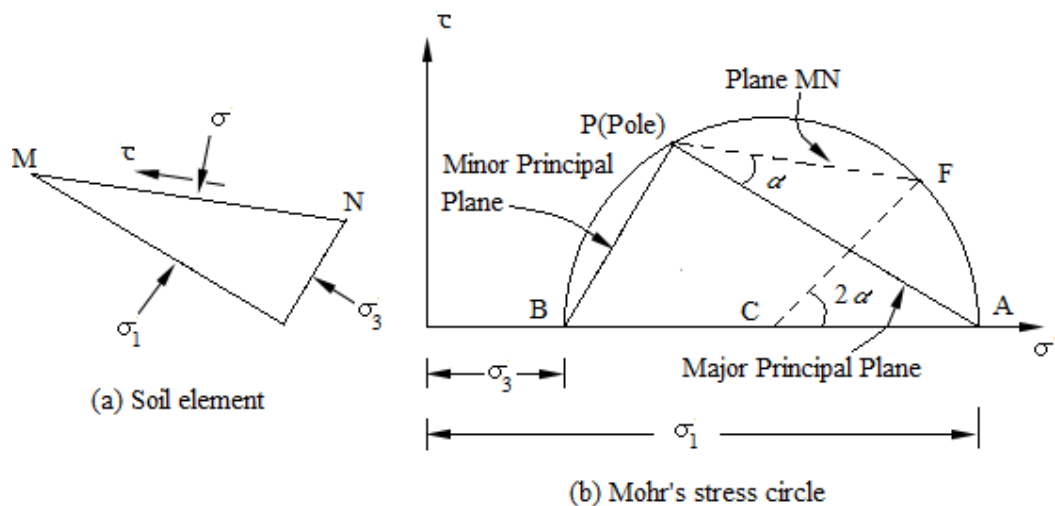

Figure 3 Mohr's stress circle

Mohr-Coulomb Theory of Failure

Various theories of failure of soil have been proposed by many soil scientists. Of these, the one proposed by Coulomb and generalised by Mohr has been the most useful for failure problems dealing with soil and hence has got wide acceptance amongst the soil scientists. This failure theory is known as Mohr-Coulomb failure theory.

According to Mohr, the failure of soil along a plane takes place when the shear stress on that plane exceeds the shear resistance of the soil. The shear resistance is a function of the normal stress on the failure plane. It is expressed as

$$\tau_f = S = f(\sigma)$$

Where $\tau_f = S =$ Shear stress at failure = Shear resistance

If the normal stress and shear stress are plotted, a curve is obtained. This curve is called the shear envelope. Coulomb assumed the relationship between τ_f and σ as linear and gave the following strength equation.

$$S = C + \sigma \tan \phi$$

For most of the cases of stability of soil, Mohr's failure can be approximated as a straight line for practical purposes and thus agrees with the above strength equation given by Coulomb.

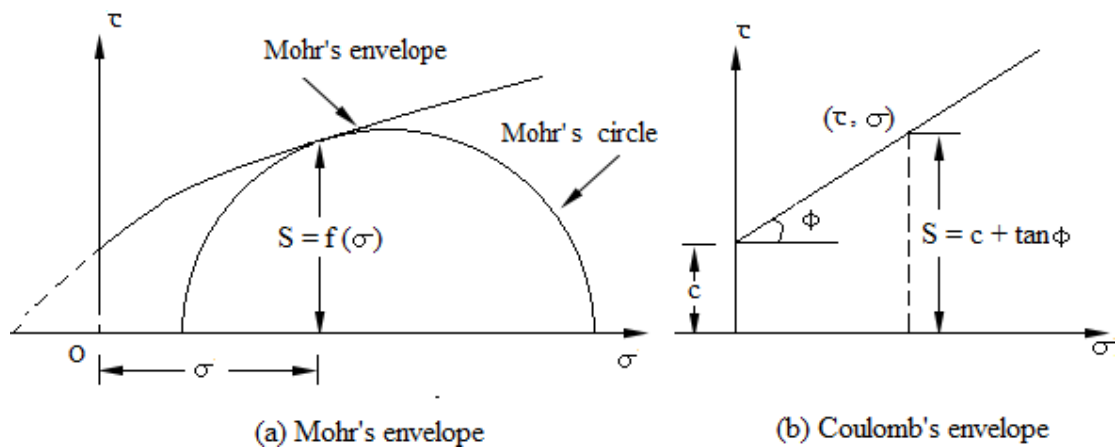

Figure 4

C and ϕ in the expression $S = C + \sigma \tan \phi$ are empirical constants and are as cohesion and angle of friction or shearing resistance. In general the above constants are known as shear strength parameters.

Depending upon the nature of soil and the shear strength parameters, soils can be described as (i) cohesive soil, (ii) cohesion-less soil, and (iii) purely cohesive soil. The strength envelopes for the three cases are shown in the Figure 5.

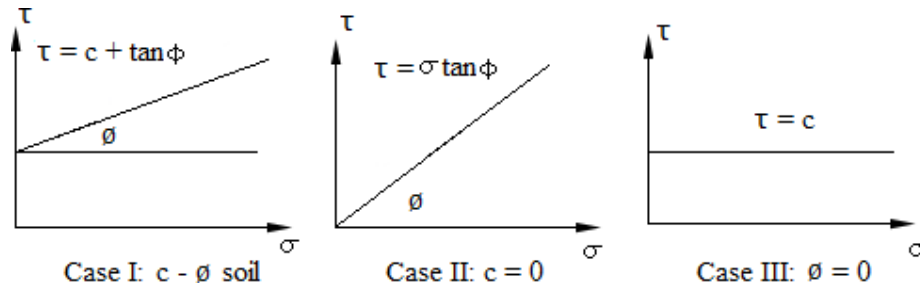

Figure 5 Strength envelopes for three types of soils

Effective stress principle

Extensive experimental studies on remoulded clays have shown the shearing strength of soil mass is controlled by the effective stress and not by the total normal stress on the plane of shear. The values of shear parameters, i.e., cohesion and angle of shearing resistance do depend upon the pore water pressure of the soil. Therefore, the Mohr-Coulomb strength equation may be expressed in terms of effective stress.

$$\tau_f = C' + \sigma' \tan \phi'$$

Where c' and ϕ' are termed as effective shear parameters.

In terms of total stresses, the equation takes the form

$$\tau_f = C_u + \sigma \tan \phi_u$$

Where C_u is the apparent cohesion and ϕ_u is the apparent angle of shearing resistance

Determination of failure plane

Failure of soil may not take place along the plane of maximum shear stress. The failure will take place along the most dangerous plane called failure plane. The failure plane is the one on which the difference between shear strength and shear stress, i.e., $(\tau_f - \tau)$ is minimum. To determine the angle of failure plane with the major principal plane, let us express the normal stress σ' and shear stress τ' on any plane inclined at an angle of α to the major principal plane.

$$\sigma' = \frac{\sigma'_1 + \sigma'_3}{2} + \frac{\sigma'_1 - \sigma'_3}{2} \cos 2\alpha$$

$$\tau' = \frac{\sigma'_1 - \sigma'_3}{2} \sin 2\alpha$$

The equation of shear strength is given by

$$\begin{aligned} \tau_f &= C' + \sigma' \tan \phi' \\ &= C' + \left[\frac{\sigma'_1 + \sigma'_3}{2} + \frac{\sigma'_1 - \sigma'_3}{2} \cos 2\alpha \right] \tan \phi' \end{aligned}$$

$$\text{So, } (\tau_f - \tau) = C' + \frac{\sigma'_1 + \sigma'_3}{2} \tan \phi' + \frac{\sigma'_1 - \sigma'_3}{2} \cos 2\alpha \tan \phi' - \frac{\sigma'_1 - \sigma'_3}{2} \sin 2\alpha$$

For minimum value of $(\tau_f - \tau)$, $\frac{d}{d\alpha} (\tau_f - \tau) = 0$

Differentiating $(\tau_f - \tau)$ with respect to α

$$\frac{d}{d\alpha} (\tau_f - \tau) = -(\sigma'_1 - \sigma'_3) \sin 2\alpha \tan \phi' - (\sigma'_1 - \sigma'_3) \cos 2\alpha$$

$$\cos 2\alpha = -\sin 2\alpha \tan \phi'$$

$$\cot 2\alpha = \cot(90 + \phi')$$

$$\alpha = \alpha_f = 45^\circ + \frac{\phi}{2}$$

where α_f is the angle of failure plane with respect to major principal plane.

The above expression for location of failure plane can be directly derived from Mohr's circle shown in Figure 6. EF represents the failure envelope given by the straight line $\tau_f = C' + \sigma' \tan \phi'$. P is the pole with stress coordinates $(\sigma'_3, 0)$. The Mohr's circle is tangential to the Mohr envelope at the point F . PF represents the direction of failure plane, inclined at an angle α_f with the direction of major principal plane. From the geometry of Figure 6, we get from triangle EFK .

$$2\alpha_f = 90^\circ + \phi'$$

$$\alpha_f = 45^\circ + \frac{\phi'}{2}$$

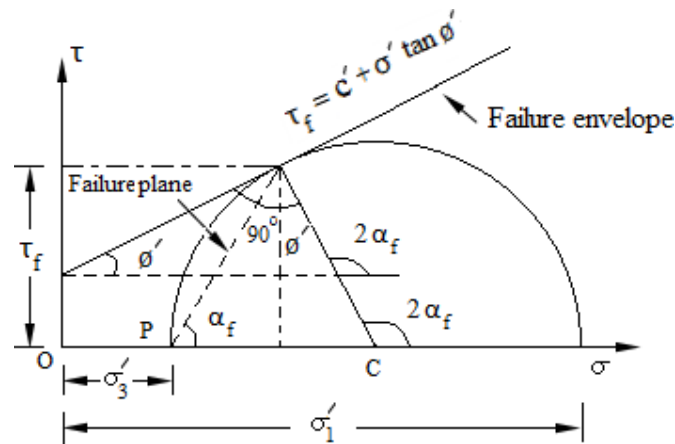

Figure 6

It may be noted that any point on the failure envelope represents two stress components σ' and τ_f at failure. And for each σ' and τ_f , there exists two values of principal effective stress on two principal planes for which failure takes place. It is evident from Figure 5 that τ_f at failure is less than the maximum shear stress, corresponding to the point G , and acting on the plane PG . Thus the failure plane does not carry maximum shear stress, and the plane which has the maximum shear stress is not the failure plane.

Determination of shear strength parameters

Shear tests are conducted on undisturbed soil samples obtained from the field. The test results are used to plot failure envelope to determine the shear strength

parameters. It is to be noted that the shear strength parameters are fundamental properties of soil and are considered as coefficients obtained from the geometry of the strength envelope drawn by using shear test results. So, during test on saturated samples, care should be taken to simulate the field drainage condition.

Following four methods of shear tests are commonly used in the laboratory.

1. Direct shear test
2. Triaxial compression test
3. Unconfined compression test
4. Vane shear test

Based on the drainage conditions, the shear tests are classified as

1. Consolidated drained test (Drained test/Quick test)
2. Consolidated undrained test
3. Unconsolidated undrained test

1. Consolidated drained test

This is also known as drained test. In this test drainage of water is allowed during the test. The soil sample is first consolidated fully under the normal load (in direct shear test) or the all round pressure (in triaxial test) and the shear stress is applied slowly enough for the water in the sample to drain away. This simulates the long term conditions in the life of a structure, i.e., the long term stability of earth dam. The effective stress parameters are used.

2. Consolidated undrained test

In this test, the soil is consolidated under the normal load or the all-round pressure but shearing is done rapidly so that drainage does not take place. This simulates the sudden effects during the life of a structure, e.g., sudden drawdown of upstream water level in an earth dam. The parameters used are C_u and ϕ_u . If pore pressure measurements are made then effective stress parameters can be used.

3. Unconsolidated undrained test

In this case, the normal load or the all-round pressure as well as shear stress are applied under conditions of no drainage. The soil is not consolidated and shearing is done rapidly. Therefore, effective stresses and hence the shear strength of the soil do

not get mobilised. This simulates short term failure conditions in a structure, e.g., stability of an earth dam immediately after construction. The total stress parameters are used for these cases.

Direct shear test

The direct shear test apparatus consists of (i) shear box of square or circular section, (ii) loading yoke for applying normal force, (iii) geared jack for applying shear force, (iv) proving ring to measure shear force, and (v) strain gauges to measure horizontal displacement and vertical displacement for volume change.

The shear box consists of two halves which can slide relative to each other. The lower half is rigidly held in position with the bottom of the shear box container, which slides on rollers when pushed by a jack provided to apply shear force. The geared jack may be driven either by electric motor or by hand. The upper half of the box is butt against a proving ring. The soil sample is placed and compacted in the shear box. The sample held in position between a pair of metal grids and porous stones or plates as shown in the Figure 7. The grid plates, provided with linear slots, are placed above the top and below the bottom of the specimen. To have proper grip with the soil specimen, the linear slots in the grid plate are aligned perpendicular to the direction of the shearing force. The soil specimen is compacted in shear box by clamping together with the help of two screws provided for the purpose. However, these screws are removed before shearing force is applied. Direct shear test may be of two types. Strain controlled shear box and stress controlled shear box. The working principles of two types of shear box are explained in the following paragraphs.

In case of strain controlled shear test a normal load N is applied on the specimen by means of loading yoke and is kept constant throughout the test. The shearing strain is increased at a constant rate by pushing the lower box through the geared jack. The movement of lower part of the box is transmitted through the specimen to the upper part of the box. The proving ring attached to the upper part reads the shear force F at failure. A number of tests are conducted on identical specimens with increased normal loads and the corresponding shear force recorded. A graph is plotted between the shear force F as ordinate and the normal load N as the abscissa. The plot so obtained is known as the failure envelope. Figure 8(b) shows the failure envelope plotted as a

function of shear stress (τ) and the normal stress (σ). The scale of both τ and σ are kept equal to measure the angle of shearing resistance (ϕ) directly from the plot.

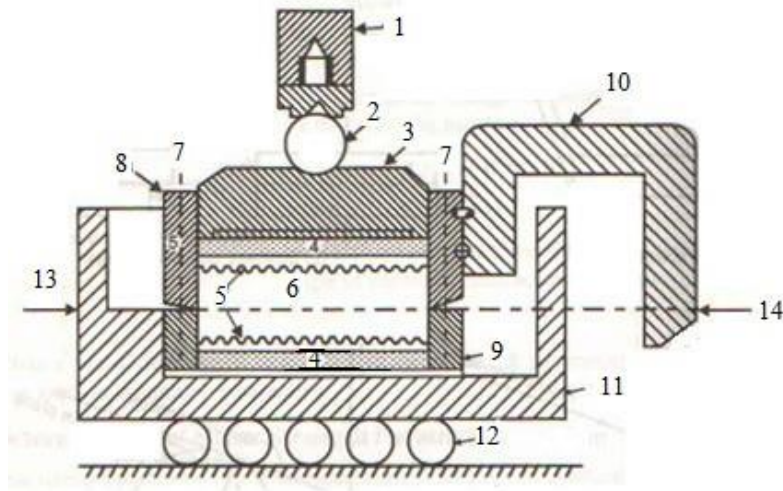

Figure 7 Shear box with accessories

- | | |
|--|--|
| 1. Loading yoke | 8. Upper part of shear box |
| 2. Steel ball | 9. Lower part of shear box |
| 3. Loading pad | 10. U-arm |
| 4. Porous stones | 11. Container for shear box |
| 5. Metal grids | 12. Rollers |
| 6. Soil specimen | 13. Shear force applied by jack |
| 7. Pins to fix two halves of shear box | 14. Shear resistance measured by proving ring dial gauge |

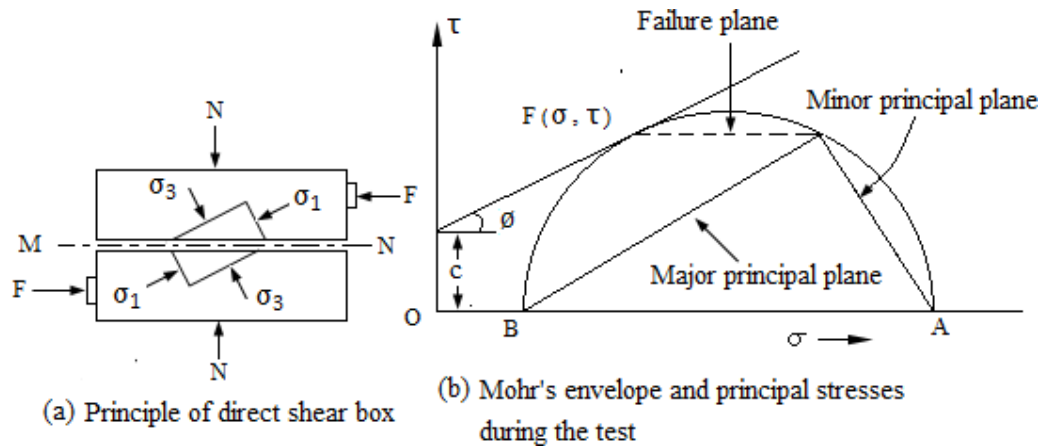

Figure 8 Shear box test

Advantages of direct shear test

1. Direct shear test is a simple test compared to the more complex triaxial test.
2. As the thickness of sample is small, it allows quick drainage and rapid dissipation of pore pressure during the test.

Disadvantages of direct shear test

1. The distribution of normal stresses and shear stresses over the potential failure plane is not uniform. The stress is more at the edges and less at the centre. Hence, progressive shear failure takes place as the shear strength is not mobilised simultaneously at all points on the failure plane.
2. The failure plane is predetermined, which may not be the weakest plane.
3. The area under shear gradually decreases as the test progresses. The corrected area at failure, A_f should be used for computing the values of normal stress σ and shear stress τ .
4. There is little control on the drainage of pore water of soil as compared to the triaxial test.
5. The stress on account of lateral restraint due to side walls of shear box is not accounted for in the test.
6. There is no provision for measurement of pore water pressure.

Problem 1.

From a direct shear test on undisturbed soil sample, following data have been obtained. Evaluate the undrained shear strength parameters. Determine shear strength, major and minor principal stresses and their planes in the case of specimen of sample subjected to a normal stress of 100 kN/m².

Normal stress (kN/m ²)	70	96	114
Shear stress at failure(kN/m ²)	138	156	170

Solution.

Plot the shear stress versus normal stress to obtain the failure envelope keeping the scale same for both the stresses. From the plot in Figure 9,

The angle of shearing resistance, $\phi = 36^0$; cohesion, $c = 84 \text{ kN/m}^2$

The shear strength corresponding to the normal stress of 100 kN/m² is 160 kN/m². The coordinate corresponding to (100, 160) is the failure point F . Draw the Mohr's circle so that the failure envelope is tangent to the circle at F . To do so, draw FC perpendicular to the failure envelope. With C as centre and CF as radius, draw a circle so as to intersect the normal load axis at A and B . Point A corresponds to the major principal stress $\sigma_1 = 410 \text{ kN/m}^2$ and point B corresponds to the minor principal stress $\sigma_3 = 20 \text{ kN/m}^2$.

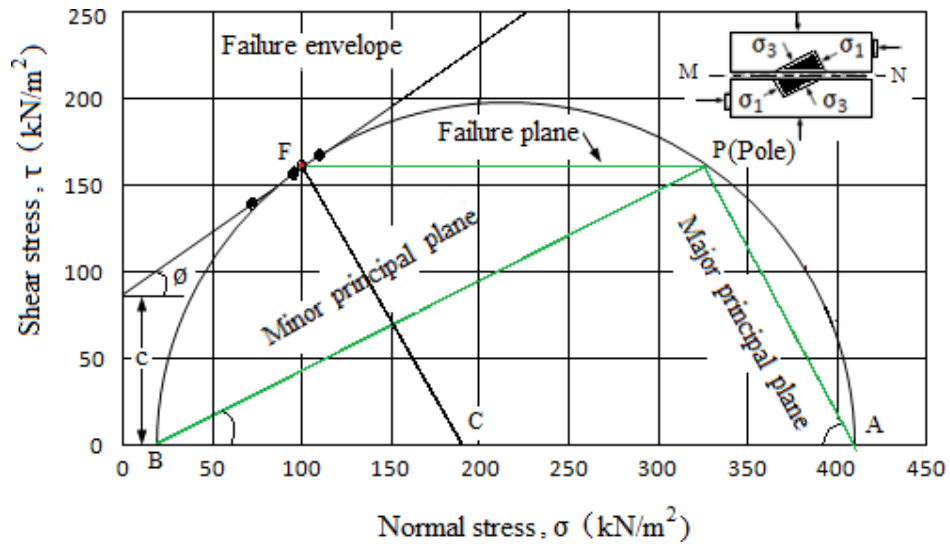

Figure 9

To locate the position of the pole, draw a line FP parallel to the failure plane in the shear box (horizontal). P is the pole. PA is the direction of major principal plane which makes an angle 57° in the clockwise direction with the plane of shear. PB is the minor principal plane, making an angle of 58° in the anticlockwise direction with the plane of shearing.

Problem 2.

A sample of cohesionless sand in a direct shear test fails under a shear stress of 160 kN/m^2 when the normal stress is 140 kN/m^2 . Find the angle of shearing resistance and the principal stress at failure.

Solution.

Plot the failure envelope passing through the origin and the point with coordinate $(140, 160)$ as normal stress and shear stress coordinates. The scale for both the stress axes are kept the same.

From the plot in the Figure 10,

The angle of shearing resistance, $\phi = 48.8^\circ$; cohesion, $c = 0$

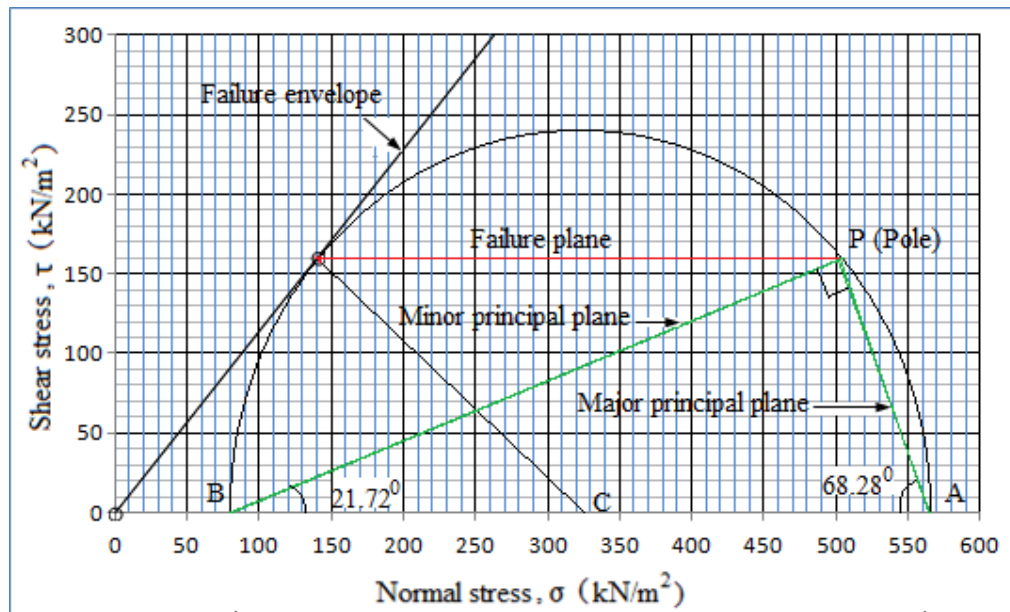

Figure 10

Draw the Mohr's circle so that the failure envelope is tangent to the circle at F . To do so, draw FC perpendicular to the failure envelope. With C as centre and CF as radius, draw a circle so as to intersect the normal load axis at A and B . Point A corresponds to the major principal stress $\sigma_1 = 565.81 \text{ kN/m}^2$ and point B corresponds to the minor principal stress $\sigma_3 = 80.35 \text{ kN/m}^2$.

To locate the position of the pole, draw a line FP parallel to the failure plane in the shear box (horizontal). P is the pole. PA is the direction of major principal plane which makes an angle 68.28° in the clockwise direction with the plane of shear. PB is the minor principal plane, making an angle of 21.72° in the anticlockwise direction with the plane of shearing.

Problem 3.

A cylinder of soil fails under an axial stress of 80 kN/m^2 . The failure plane makes an angle of 48° with the horizontal. Calculate the value of cohesion and the angle of internal friction of the soil. Verify by graphical method.

Solution.

As there is only axial stress, there is no lateral stress acting on the soil, i.e., it is unconfined compression failure. Hence, minor principal stress $\sigma_3 = 0$ and major principal stress $\sigma_1 = 60$.

And $\alpha = 48^\circ$

We know,

$$\sigma_1 = \sigma_3 \tan^2 \alpha + 2c \tan \alpha$$

$$80 = 0 \times \tan^2 \alpha + 2c \tan 48$$

$$80 = 2c \tan 48$$

$$c = 36.02 \text{ kN/m}^2$$

Again,

$$\alpha = 45^\circ + \frac{\phi}{2}$$

$$\phi = (\alpha - 45) \times 2$$

$$\phi = (48 - 45) \times 2$$

$$\phi = 6^\circ$$

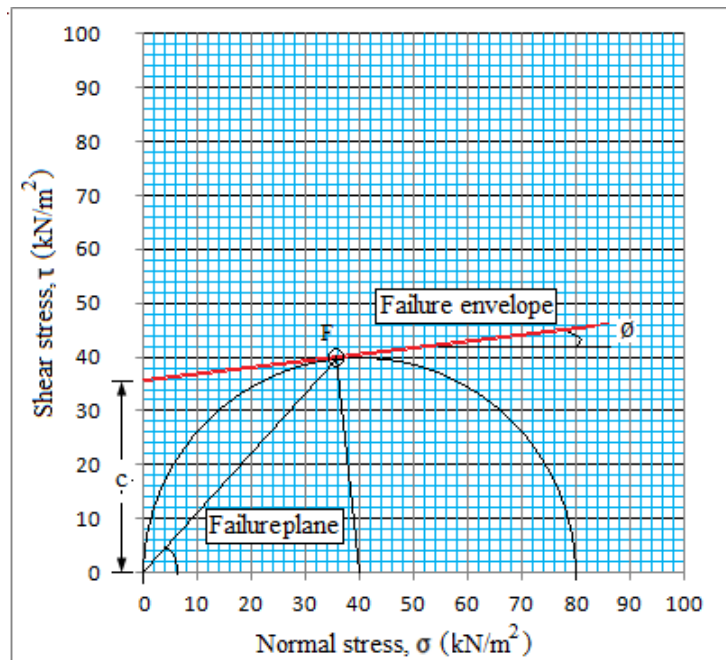

Figure 11

The Mohr's stress circle is drawn with radius $\frac{\sigma_1 - \sigma_3}{2} = \frac{80 - 0}{2} = 40$. The circle passes through the origin representing the minor principal stress which is also the pole. Failure plane is drawn through the pole O so as to intersect the Mohr's circle at F . Join F with the centre C of the Mohr's circle. Draw the failure envelope by drawing a tangent at F on the circle so as to intersect the y -axis. The slope $\phi = 6^\circ$ of the failure plane is the angle of shearing resistance. The y -intercept $c = 36.02 \text{ kN/m}^2$ is the cohesion.

Triaxial compression test

Triaxial shear test is the most extensively used for computation of shear strength parameters. In this test, the specimen is compressed by applying all the three principal stresses, σ_1, σ_2 and σ_3 .

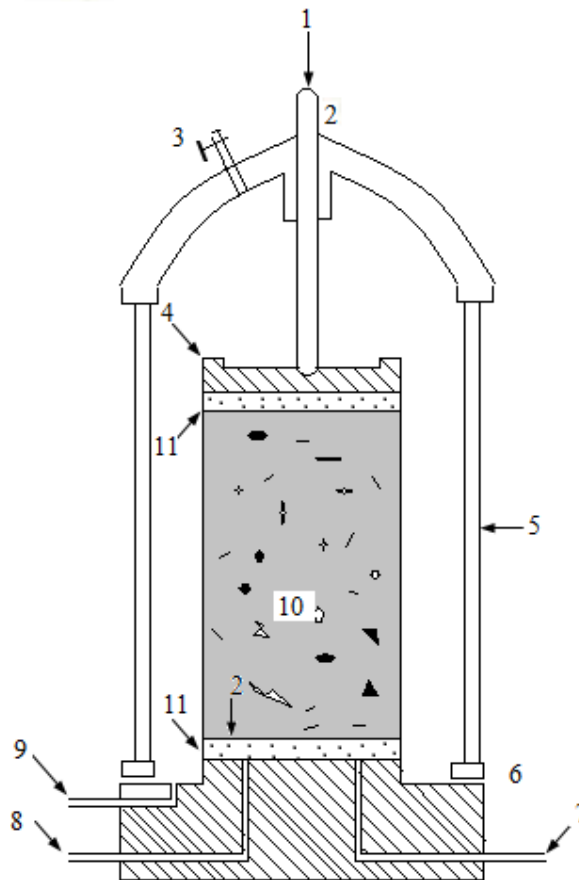

Figure 12 Triaxial cell

1. Axial load measured by proving ring dial gauge
2. Loading arm
3. Air release valve
4. Top cap
5. Perspex cylinder
6. Sealing ring
7. Pore water outlet
8. Additional pore water outlet
9. Cell fluid inlet
10. Soil specimen enclosed in rubber membrane
11. Porous disc

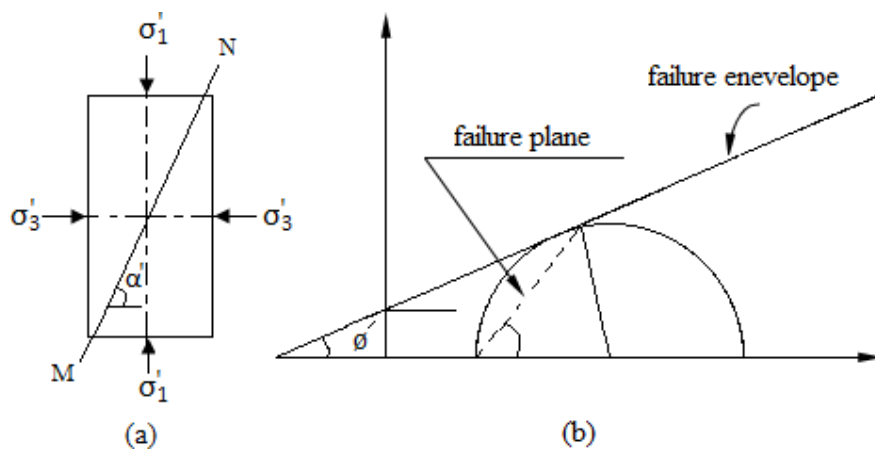
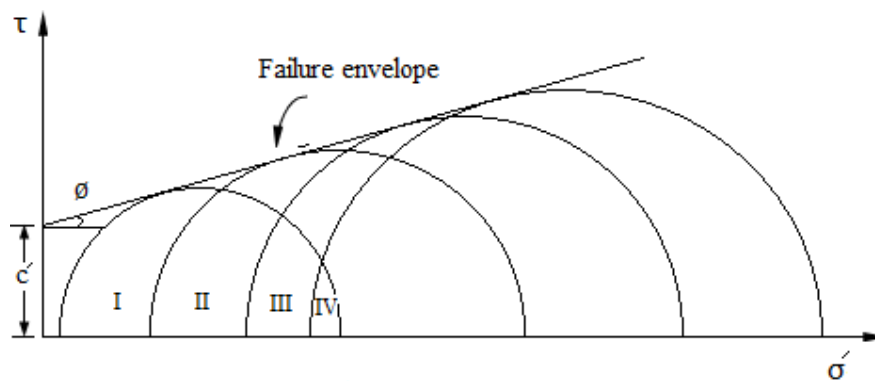

Figure 13 Stress condition and failure envelope in triaxial compression test



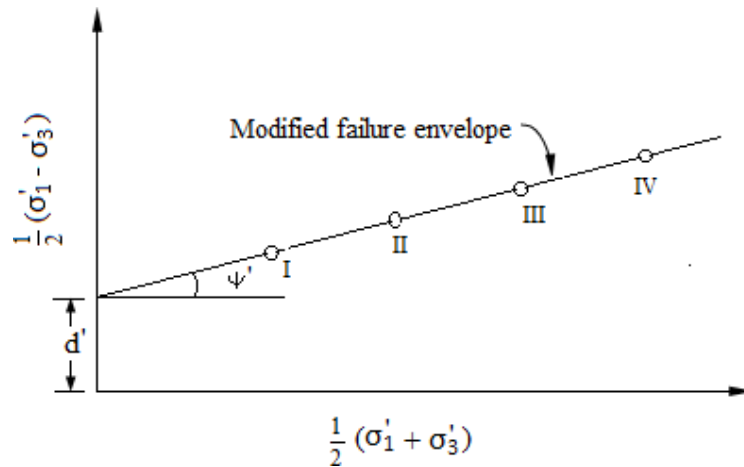

Figure 14 Failure envelopes

Advantages of triaxial compression test

Followings are the advantages of triaxial compression test over the direct shear test.

1. Unlike the direct shear test in which the soil sample is forced to fail along a predetermined plane, the specimen in triaxial compression is free to fail along the weakest plane.
2. Distribution of stress is uniform along the failure plane is uniform. The shear strength is mobilized uniformly at all points on the failure plane.
3. The test procedure has complete control of the drainage conditions. The field drainage conditions are better simulated in triaxial compression test as compared to direct shear test.
4. Precise measurements of pore pressure and volume change are possible during the test.
5. The effect of end restraint does not have considerable effect on the result as failure usually occurs near the middle of the sample.

Unconfined compression test

Unconfined compression test is a special case of triaxial compression test in which no lateral or confining stress ($\sigma_2 = \sigma_3 = 0$) is applied. A cylindrical soil sample of length 2 to 2.5 times the diameter is used as test sample. The soil specimen is only to

the major principal stress σ_1 till the specimen fails due to shearing along a critical failure plane.

Figure 15 shows the simplest form of compression testing machine. It consists of a small load frame fitted with a proving ring to measure the vertical stress σ_1 applied to the soil specimen. A separate dial gauge is used to measure the deformation of the sample.

The sample is conically hollowed at its ends and placed between two conical seatings attached to two metal plates. The conical seatings reduces end restraints and prevents the tendency of the specimen to become barrel shaped. The load is applied through a calibrated spring by manually operated screw jack at the top of the machine. The test sample is compressed at uniform rate of strain by the compression testing equipment. The axial deformation and the corresponding axial compressive force are measured. the sample may undergo brittle failure or plastic failure. In case of brittle failure, a definite maximum load is indicated by the proving ring which decreases rapidly with further increase of strain. However, no definite maximum load is indicated by the proving ring dial in case of a plastic failure. In such a case, the load corresponding to 20% strain is arbitrarily taken as the failure load. The maximum axial compressive stress resisted by the specimen before failure is called the unconfined compressive strength.

The unconfined compression test is a quick test in which no drainage is allowed. Since $\sigma_3 = 0$, the Mohr's circle passes through the origin, which is the pole. Figure 16 shows the stress conditions in a typical unconfined compression test. The equation plastic equilibrium may be expressed as

$$\sigma_1 = 2c_u \tan \alpha = 2c_u \tan \left(45^\circ + \frac{\phi_u}{2} \right)$$

In the above equation, there are two unknowns c_u and ϕ_u , and cannot be determined by the unconfined test since a number of test on the identical specimens give the same value of σ_1 . Hence, the unconfined compression test is generally conducted on saturated clay for which the apparent angle of shearing resistance $\phi_u = 0$. Hence

$$\sigma_1 = 2c_u$$

The radius of the Mohr's circle is $\frac{\sigma_1}{2} = c_u$, The failure envelope is horizontal. PF is the failure plane, and the stresses on the failure plane are

$$\sigma = \frac{\sigma_1}{2} = \frac{q_u}{2}$$

$$\tau_f = \frac{\sigma_1}{2} = \frac{q_u}{2} = c_u$$

where q_u is the unconfined compressive strength at failure. The compressive stress

$q_u = \frac{F}{A_c}$ is calculated on the basis of changed cross-sectional area A_c at failure, which

is given by

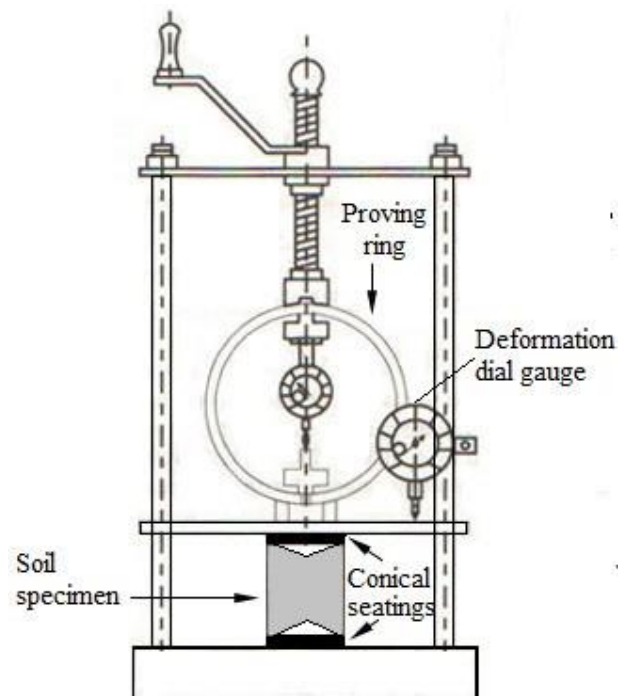

Figure 15 Unconfined Compression test set up

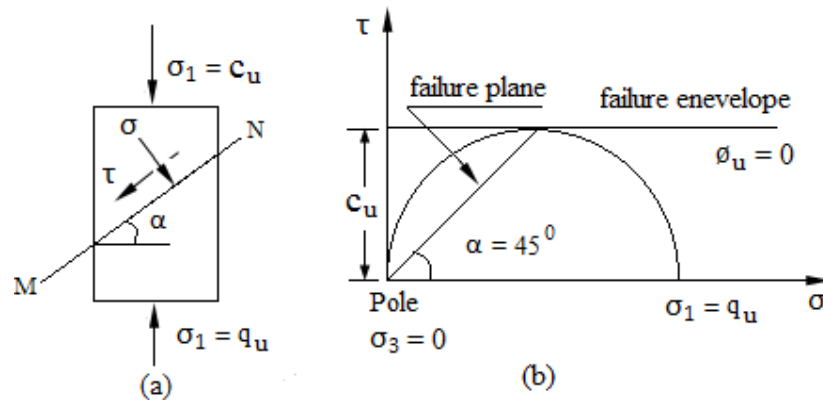

Figure 16 Unconfined compression test

$$A_c = \frac{V}{L_0 - \Delta L} = \frac{A_0}{1 - \frac{\Delta L}{L_0}}$$

$$A_c = \frac{A_0}{1 - \epsilon}$$

Where A_c = corrected area of cross section specimen

A_0 = initial area of cross section of specimen

L_0 = initial length of the specimen

V = initial volume of the specimen

ΔL = change in length at failure

$\epsilon = \frac{\Delta L}{L_0}$ = axial strain at failure

CHAPTER-8

EARTH PRESSURE ON RETAINING STRUCTURES

In 1929 Terzaghi (The Father of Soil Mechanics) conducted experiments on the retaining wall and showed the relation of pressure on the wall if wall changes its position i.e to move inwards to the backfill, outwards of it or remain at its place. **There are three types of earth pressures on the basis of the movement of the wall.**

1. Earth Pressure at rest
2. Active Earth Pressure
3. Passive Earth Pressure

These are explained below

Pressure at rest:

When the wall is at rest and the material is in its natural state then the pressure applied by material is known as Earth Pressure at Rest. It is represented by P_0 .

Active earth pressure:

When the wall moves away from the backfill, there is a decrease in the pressure on the wall and this decrease continues until a minimum value is reached after which there is no reduction in the pressure and the value will become constant. This kind of pressure is known as active earth pressure.

Passive earth pressure:

When the wall moves towards the backfill, there is an increase in the pressure on the wall and this increase continues until a maximum value is reached after which there is no increase in the pressure and the value will become constant. This kind of pressure is known as passive earth pressure. This means that when the wall is about to slip due to lateral thrust from the backfill, a resistive force is applied by the soil in front of the wall.

Alternatively :-

Earth pressure is the force per unit area exerted by soil. The ratio of horizontal to vertical stress is called coefficient of lateral earth pressure (K).

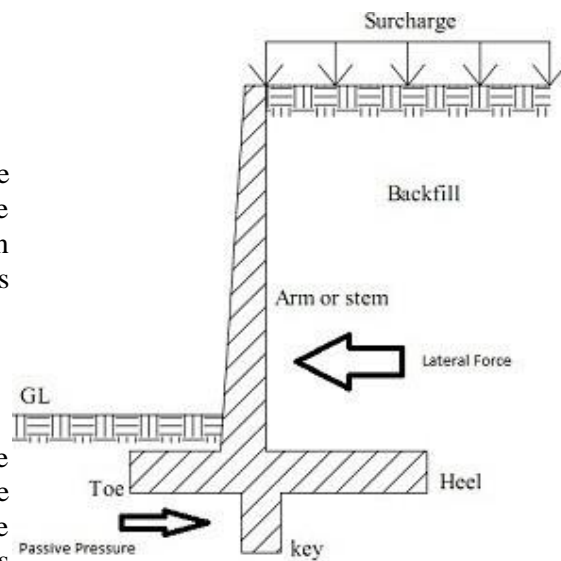

Figure 1: Retaining Wall

$$K = \frac{\sigma'_h}{\sigma'_v}$$

Earth pressure forces can be at-rest (Fig a), active (b) or passive (c).

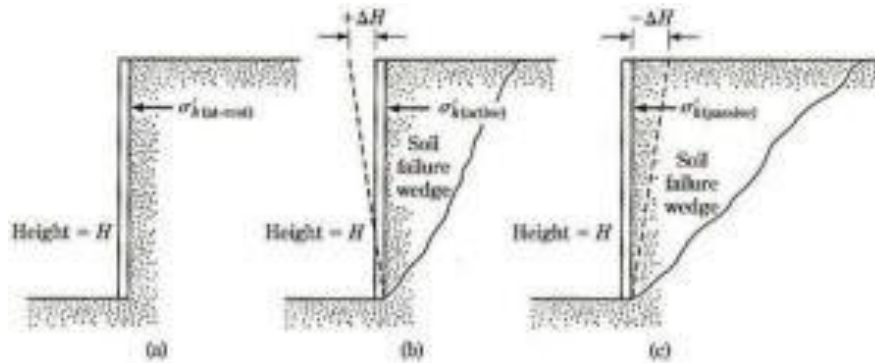

FIG-2

Typical range of lateral earth pressure coefficients

Condition	Granular Soil	Cohesive Soil
Active	0.20 – 0.33	0.25 – 0.5
Passive	3 – 5	2 – 4
At-Rest	0.4 – 0.6	0.4 – 0.8

At-Rest Earth Pressure

Under conditions of zero horizontal displacement, the soil is said to be at-rest:

When the retaining wall is at rest then the ratio between the lateral earth pressure and the vertical pressure is called the co-efficient of the earth pressure at rest,

$$K_o = \text{lateral pressure} / \text{vertical pressure}$$

$$K_o \approx 1 - \sin \Phi' \text{ (granular soils)}$$

Active Earth Pressure

For a level backfill ($\beta = 0$), the following equation is used to determine the active earth pressure (p_a) for all types of soils.

When the retaining wall is moving away from the backfill the the ratio between lateral earth pressure and vertical earth pressure is called co-efficient of active earth pressure.

$$K_a = \text{lateral pressure} / \text{vertical pressure}$$

$$p_a = K_a \gamma H - 2c \sqrt{K_a}$$

For saturated clay soils, $\Phi = 0$; $K_a=1$: $p_a = \gamma H - 2c$

For granular soils, $c=0$: $p_a = K_a \gamma H$

The critical depth, Z_{cr} , which is the depth at which the horizontal pressure is zero, can be estimated by:

$$z_{cr} = \frac{2c}{\gamma \sqrt{K_a}}$$

The total active resultant force (without surcharge or cohesion) is solved for by:

$$R_a = \frac{1}{2} p_a H = \frac{1}{2} K_a \gamma H^2$$

Passive Earth Pressure

For a level backfill ($\beta = 0$), the following equation is used to determine the passive earth pressure for all types of soils.

When the retaining wall is moving towards the backfill, then the ratio between the lateral earth pressure and the vertical earth pressure is called the Co-efficient of passive earth pressure.

$K_p = \text{lateral pressure} / \text{vertical pressure}$

$$p_p = K_p \gamma H + 2c \sqrt{K_p}$$

For saturated clay soils, $\phi = 0$, $K_p = 1$: $p_p = \gamma H + 2c$

For granular soils, $c = 0$: $p_p = K_p \gamma H$

The total passive resultant force (without surcharge or cohesion) is solved for by:

$$R_p = \frac{1}{2} p_p H = \frac{1}{2} K_p \gamma H^2$$

Surcharge:

The material which lies above the horizontal level of the retaining structure is known as surcharge. The angle which this material makes with the retaining wall is called surcharge angle.

8.2- Use of Rankine's formula for the following cases (cohesion-less soil only)

Assumptions made by Rankine for the derivation of earth pressure .

- The soil mass is homogeneous and semi-infinite.
- The soil is dry and cohesionless.
- The ground surface is plane, which may be horizontal or inclined.
- The back of the retaining wall is smooth and vertical.
- The soil element is in a state of plastic equilibrium, i.e., at the verge of failure

ACTIVE EARTH PRESSURE:

1. Backfill with no surcharge

Let us consider an element of dry soil at a depth Z below a level soil surface. Initially , the element is at rest conditions, and the horizontal pressure is given by

$$\sigma_h = k_0 \sigma_v$$

Where σ_v is the vertical stress at C , and σ_h is the horizontal stress at C . Of course, $\sigma_v = \gamma Z$.

The stresses σ_h and σ_v are respectively minor and major principal stresses, and are indicated by points A and B in the Mohr circle in fig 2.b .

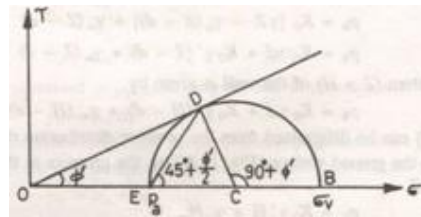

Let us now consider the case when the vertical stress remains constant while the horizontal stress is decreased. The point A shifts to position A' and the diameter of the Mohr circle increases. In the limiting condition , the point A shifts to the position A'' when the Mohr circle [marked (3)] touches the failure envelope. The soil is at the verge of shear failure. It has attained the Rankine's active state of plastic equilibrium. The horizontal stress at that state is the active pressure(P_a).

Fig.2.c shows the Mohr circle when active conditions are developed. Point E represents the active condition. From the figure,

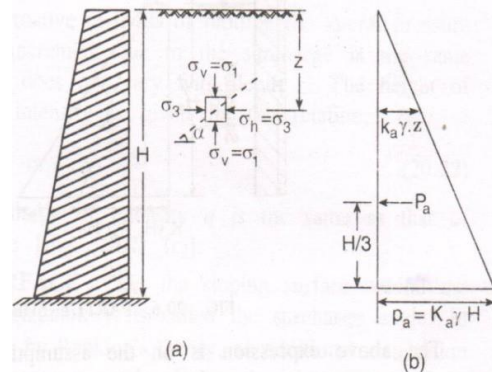

ACTIVE EARTH PRESSURE OF DRY OR MOIST COHESIONLESS SOIL.

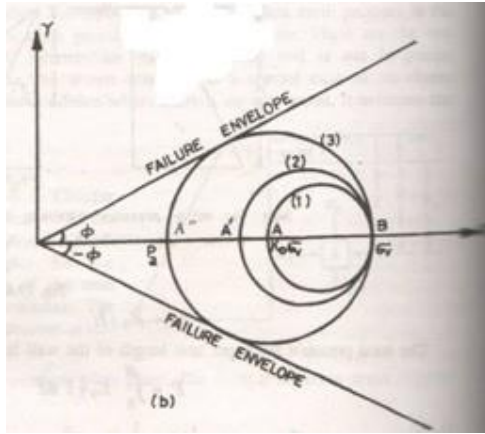

FIG 2.(b)

$$P_a = OE = OC - CE$$

$$CE = CD = OC \sin \phi',$$

$$P_a = OC - OC \sin \phi' = OC(1 - \sin \phi') \quad \dots(a)$$

$$\sigma_v = OB = OC + CB = OC + OC \sin \phi'$$

$$\sigma_v = OC(1 + \sin \phi') \quad \dots(b)$$

From Eqs. (a) and (b),

$$\frac{P_a}{\sigma_v} = \frac{1 - \sin \phi'}{1 + \sin \phi'}$$

$$P_a = \left(\frac{1 - \sin \phi'}{1 + \sin \phi'} \right) \sigma_v$$

$$P_a = K_a \gamma z \quad \dots(c)$$

FIG 2.(c)

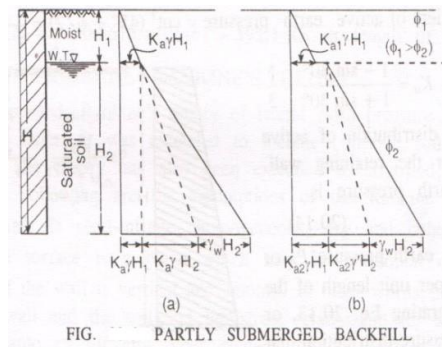
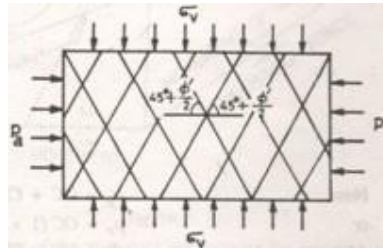

FIG 2.(e)

Where K_a is a co-efficient of active earth pressure . It is a function of the angle of shearing

resistance (ϕ'), and is $\tan^2 45^\circ - \frac{\phi'}{2}$



$$\text{given by } K_a = \left(\frac{1 - \sin \phi'}{1 + \sin \phi'} \right) =$$

Fig.2.e shows the inclined at $(45^\circ + \phi/2)$

failure planes. These are to the major principal plane which is horizontal. The total active earth pressure P_a or the resultant pressure per unit length of the of the wall is found by integrating or from the triangular pressure distribution diagram.

$$P_a = \frac{1}{2} K_a \gamma H^2 \text{ acting at } H/3 \text{ from the base of the wall.}$$

If the soil is dry , γ is the dry unit weight of the soil, and if wet, γ is the moist weight.

2. Backfill with uniform surcharge

If the backfill is horizontal and carries a surcharge of uniform intensity q per unit area, the vertical pressure increment, at any depth Z , will increase by q . The increase in the lateral pressure due to this will be $K_a q$. Hence lateral pressure at any depth Z is given by

$$P_a = K_a \gamma z + K_a q$$

At the base of the wall, the pressure intensity is

$$P_a = K_a \gamma H + K_a q$$

FIG. 3(a) and (b) shows the two alternative methods of plotting the lateral pressure diagram for this case. The lateral pressure increment due to the surcharge is the same at every point of the back of the wall, and does not vary with depth Z . The height of the fill Z_e , equivalent to the uniform surcharge intensity is given by the relation,

$$K_a \gamma z_e = K_a q, \quad z_e = \frac{q}{\gamma}$$

This means that the effect of the surcharge of intensity q is the same as that of a fill of height Z_e above the ground surface.

3. Submerged Backfill

In this case, the sand fill behind the retaining wall is saturated with water. The lateral pressure is made up of two components:

- (i) lateral pressure due to submerged weight γ' of the soil, and
- (ii) lateral pressure due to water. Thus at any depth z below the surface,

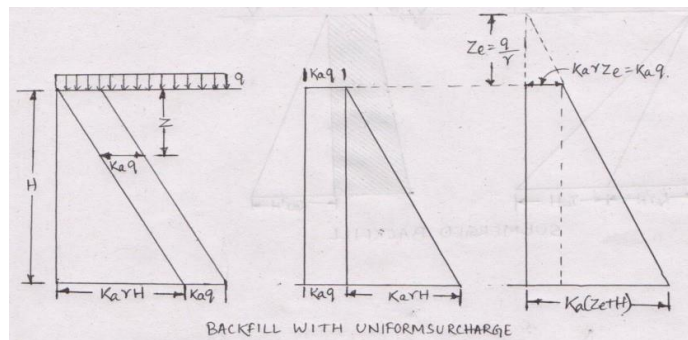

$$P_a = K_a \gamma' z + \gamma_w z$$

The pressure at the base of the retaining wall ($z = H$) is given by

$$P_a = K_a \gamma' H + \gamma_w H$$

If the free water stands to both sides of the wall, the water pressure need not be considered, and the net lateral pressure is given by

$$P_a = K_a \gamma' H$$

If the backfill is partly submerged, i.e., the backfill is moist to a depth H_1 below the ground level, and then it is submerged, the lateral pressure intensity at the base of the wall is given by

$$P_a = K_a \gamma' H_1 + K_a \gamma' H_2 + \gamma_w H_2$$

The above expression is on the assumption that the value of ϕ is the same for the moist as well as submerged soil.

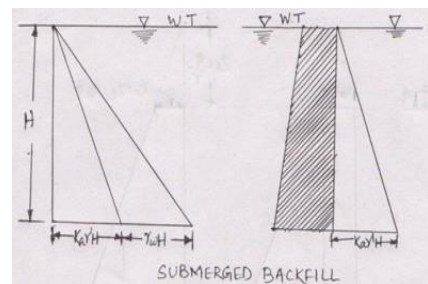

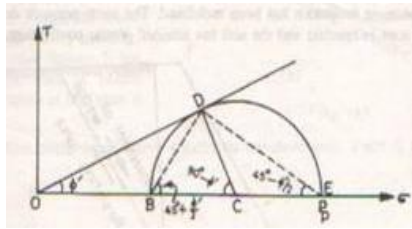

If it is different, say ϕ_1

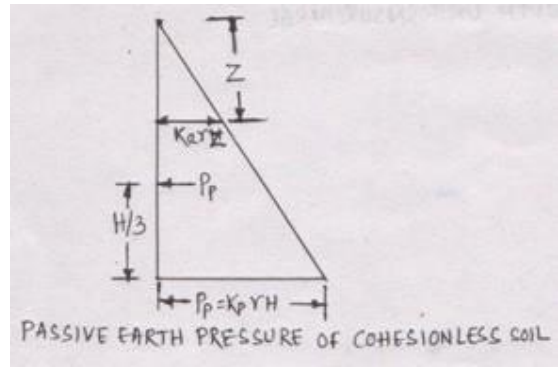

and ϕ_2 respectively, the earth pressure coefficient, K_{a1} and K_{a2} , for both the portions will be different. As ϕ decreases, K_a increases. The lateral pressure intensity at the base of wall is given by

$$P_a = K_{a1} \gamma' H_1 + K_{a2} \gamma' H_2 + \gamma_w H_2$$

PASSIVE EARTH PRESSURE

Let us consider an element of dry soil at a depth Z below a level soil surface. As the soil is compressed laterally, the horizontal stress is (σ_h) increased, where as the vertical stress (σ_v) remains constant.

The stresses σ_h and σ_v are respectively minor and major principal stresses, and are indicated by

points A and B in the Mohr circle.

The point A shifts to position A' and the diameter of the Mohr circle increases. In the limiting condition, the point A shifts to the position A'' when the Mohr circle [marked (3)] touches the failure envelope. The soil is at the verge of shear failure. It has attained the Rankine active state of plastic equilibrium. The horizontal stress at that state is the active pressure (P_p).

$$P_p = OE = OC + CE$$

$$CE = CD = OC \sin \phi'$$

$$P_p = OC + OC \sin \phi' = OC(1 + \sin \phi') \quad \dots(d)$$

$$\sigma_v = OB = OC - BC = OC - CD = OC - OC \sin \phi'$$

$$\sigma_v = OC(1 - \sin \phi')$$

$$\dots(e)$$

From Eqs. (a) and (b),

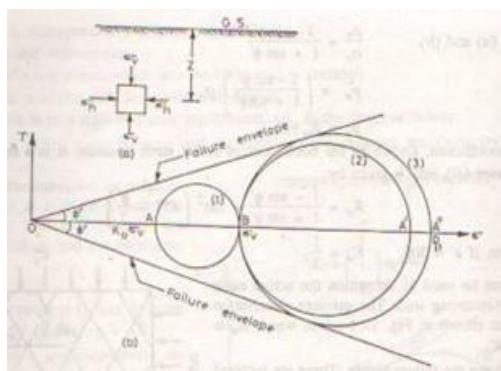

$$\frac{P_p}{\sigma_v} = \frac{1 + \sin\phi'}{1 - \sin\phi'}$$

$$P_p = \left(\frac{1 + \sin\phi'}{1 - \sin\phi'} \right) \sigma_v$$

$$P_p = K_p \gamma Z \quad \dots(f)$$

Where K_p is a co-efficient of passive earth pressure. It is a function of the angle of shearing resistance (ϕ'), and is given by

$$K_p = \left(\frac{1 + \sin\phi'}{1 - \sin\phi'} \right) = \tan^2 \left[45^\circ + \left(\frac{\phi'}{2} \right) \right]$$

Figure shows the failure planes. These are inclined at $(45^\circ + \phi'/2)$ to the major principal plane which is horizontal.

The distribution of passive earth pressure, given in Eq.(f) is triangular, with maximum value of

$K_p \gamma H$ at the base of the retaining wall of height H . The total pressure P_p for a depth H is given by

$$P_p = \int_0^H K_p \gamma Z \cdot dz$$

$$= \frac{1}{2} K_p \gamma H^2$$

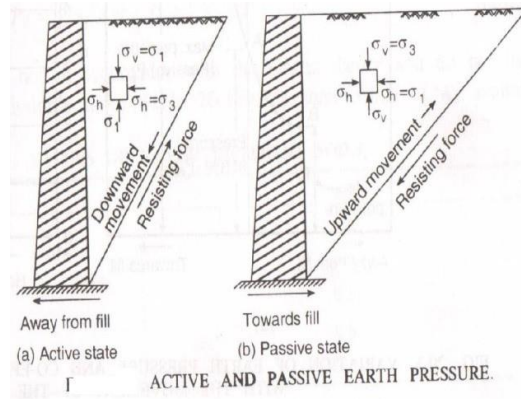

If a uniform surcharge intensity q per unit area acts over the surface of the backfill, the increase in the passive pressure will be equal to $K_p q$. The passive pressure intensity at a depth z is then given by

$$P_p = K_p (\gamma Z + q)$$

EX-1:

Compute the intensities of active and passive earth pressure at depth of 8 metres in dry cohesionless sand with an angle of internal friction of 30° and unit weight of 18 kN/m^3 . What will be the intensities of active and passive earth pressure if the water level rises to the ground level? Take saturated unit weight of sand as 22 kN/m^3 .

Solution: (a) Dry soil :

$$K_a = \left(\frac{1 - \sin\phi'}{1 + \sin\phi'} \right) = \left(\frac{1 - \sin 30^\circ}{1 + \sin 30^\circ} \right) = \frac{1}{3}; \quad K_p = \left(\frac{1 + \sin\phi'}{1 - \sin\phi'} \right) = \left(\frac{1 + \sin 30^\circ}{1 - \sin 30^\circ} \right)$$

$$P_a = K_a \gamma H = \frac{1}{3} \times 18 \times 8 = 48 \text{ kN/m}^2$$

$$P_p = K_p \gamma H = 3 \times 8 \times 8 = 432 \text{ kN/m}^2$$

(b) Submerged Backfill :

$$\gamma' = \gamma_{\text{sat}} - \gamma_w = 22 - 9.81 = 12.19 \text{ kN/m}^3$$

$$P_a = K_a \gamma' H + \gamma_w H = \frac{1}{3} \times 12.19 \times 8 + (9.81 \times 8) = 111 \text{ kN/m}^2$$

$$P_p = K_p \gamma' H + \gamma_w H = (3 \times 12.19 \times 8) + (9.81 \times 8) = 371 \text{ kN/m}^2$$

EX-2:

A retaining wall 4 m high, has a smooth vertical back. The backfill has a horizontal surface in level with the top of the wall. There is uniformly distributed surcharge load of 36 kN/m² intensity over the backfill. The unit weight of the backfill is 18 kN/m³; its angle of shearing resistance is 30° and cohesion is zero. Determine the magnitude and point of application of active pressure per metre length of the wall.

Solution:

$$K_a = \left(\frac{1 - \sin \theta'}{1 + \sin \theta'} \right) = \left(\frac{1 - \sin 30^\circ}{1 + \sin 30^\circ} \right) = \frac{1}{3};$$

The lateral pressure intensity due to the surcharge is given by

$$p_1 = K_a q = \frac{1}{3} \times 36 = 12 \text{ kN/m}^2$$

The pressure intensity due to backfill, at depth H= 4 m is given by,

$$p_2 = K_a \gamma H = \frac{1}{3} \times 18 \times 4 = 24 \text{ kN/m}^2$$

The total pressure intensity at the base of the wall is given by

$$p_a = p_1 + p_2 = 12 + 24 = 36 \text{ kN/m}^2$$

The resultant total pressure P₁ due to intensity p₁ given by :

$$P_1 = p_1 \times H = 12 \times 4 = 48 \text{ kN/ m}$$

Acting at 4/2=2 m from the base.

The resultant total pressure P₂ due to intensity p₂ given by :

$$P_2 = \frac{1}{2} \times p_2 \times H = \frac{1}{2} \times 24 \times 4 = 48 \text{ kN/ m, acting at } \frac{1}{3} \times 4 = 1.33 \text{ m from the base.}$$

$$P = P_1 + P_2 = 48 + 48 = 96 \text{ kN per metre length of the wall.}$$

The resultant P acts at a distance z above the base, given by taking the moments about the base :

$$z = \frac{(48 \times 2) + (48 \times 1.33)}{96} = 1.67 \text{ m.}$$

CHAPTER-9

FOUNDATION ENGINEERING

9.1 FOUNDATION : It is the bottom most part of the structure that remains in direct contact with soil and transmits the load of the structure underneath.

Functions of the foundation- In addition to transmitting the load of the superstructure to the soil it provides stability to the structure against overturning and erosion.

SHALLOW FOUNDATIONS

Types of Foundations may be broadly classified

under two heads: shallow foundations and deep foundation is shallow if its Terzaghi, a foundation.

According to Terzaghi, a foundation is shallow if its depth is equal to or less than its width.

In the case of deep foundation, the depth is equal to or greater than the width. Apart

from deep strip, rectangular or square foundations, other common forms of deep foundations are: pier foundation, pier foundation are and well foundation.

The shallow foundations are of the following types : spread footing (or simply, footing), strap footing, combined footing, and mat or raft footing.

Fig. shows the common types of shallow foundations.

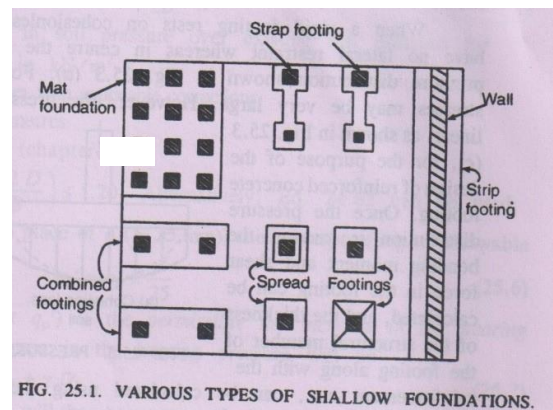

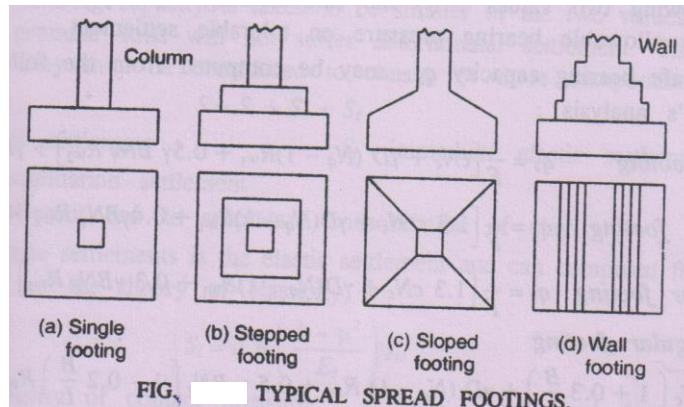

A spread footing or simply footing is a type of shallow foundation used to transmit the load of an isolated column, or that of a wall to the subsoil. This is most common type of foundation. The base of the column or wall is enlarged or spread to provide individual support for the load. Fig. shows some typical spread footings.

9.2 Bearing Capacity :

Definitions :

1. **Footing:** A footing is a portion of the foundation of a structure that transmits loads directly to the soil.
2. **Foundation:** A foundation is that part of the structure which is in direct contact with and transmit loads to the ground.
3. **Foundation soil :** It is the upper part of the earth mass carrying the load of the structure.
4. **Bearing capacity :** The supporting power of a soil or rock is referred to as its bearing capacity. The term bearing capacity is defined after attaching certain qualifying prefixes.
5. **Gross pressure intensity (q) :** The gross pressure intensity q is the total pressure at the base of the footing due to the weight of the superstructure, self-weight of the footing and the weight of the earth fill, if any.

6. **Net pressure intensity (q_n).** It is defined as the excess pressure, or the difference in intensities of the gross pressure after the construction of the structure and the original overburden pressure. Thus, if D is the depth of footing.

$$q_n = q - \bar{\sigma} = q - yD$$

Where y is the average unit weight of soil above the foundation base.

7. **Ultimate bearing capacity (q_f).** The ultimate bearing capacity is defined as the minimum gross pressure intensity at the base of the foundation at which the soil fails in shear. (When the term bearing capacity is used in this book without any prefix, it may be understood to be ultimate bearing capacity).

8. **Net ultimate bearing capacity (q_{nf}).** It is the minimum net pressure intensity causing shear failure of soil. The ultimate bearing capacity q_f and the net ultimate capacity are evidently connected by the following relation :

$$q_f = q_{nf} + \bar{\sigma} \quad \dots (9.1) \quad \text{or} \quad q_{nf} = q_f - \bar{\sigma} \quad \dots$$

9.1 (a)

Where $\bar{\sigma}$ is the effective surcharge at the base level of the foundation.

9. **Effective surcharge at the base level of foundation ($\bar{\sigma}$).** It is the intensity of vertical pressure at the base level of foundation, computed assuming total unit weight for the portion of the soil above the water table and submerged unit weight for the portion below the water table.

10. **Net safe bearing capacity (q_{ns}).** The net safe bearing capacity is the net ultimate bearing capacity divided by a factor of safety F

$$q_{ns} = \frac{q_{nf}}{F}$$

11. **Safe bearing capacity** (q_s). The maximum pressure which the soil can carry safely without risk of shear failure is called the safe bearing capacity. It is equal to the net safe bearing capacity plus original overburden pressure:

$$q_s = q_{ns} + \gamma D = \frac{q_{nf}}{F} + \gamma D$$

Sometimes, the safe bearing capacity is also referred to as the ultimate bearing capacity q_f divided by a factor of safety F .

12. **Safe bearing pressure or Net soil pressure for specified settlement.**

It is the intensity of loading that will cause a permissible settlement or specified settlement for the structure.

13. **Allowable bearing capacity or pressure** (q_a). It is the net loading intensity at which neither the soil fails in shear nor there is excessive settlement detrimental to the structure.

TYPES OF BEARING CAPACITY FAILURES:

Experimental investigations have indicated that when a footing fails due to insufficient bearing capacity, distinct failure patterns are developed, depending upon type of failure mechanism. Failure is accompanied by appearance of failure surfaces and by building of sheared mass of soil. Vesic (1963) observed three types of bearing capacity failures (fig. 9.2).

1. General shear failure, 2. Local shear failure and 3. Punching shear failure.

1. **General shear failure** : In the case of general shear failure, continuous failure surfaces develop between the edges of the footing and the ground surface, as shown in Fig. 9.2(a). When the pressure approaches the value of q_f , the state of plastic equilibrium is reached initially in the soil around the edges of the footing, and it then gradually spreads downwards and outwards. Ultimately, the state of plastic equilibrium is fully developed throughout the soil

above the failure surfaces. The failure is accompanied by appearance of failure surface and by considerable bulging of sheared mass of soil. However, the final slip movement would occur only on one side, accompanied by tilting of the footing. Such a failure occurs in soil of low compressibility, i.e. dense or stiff soil, and the pressure-settlement curve is of the general form as shown is curve a of Fig. 9.2 (d). following are the typical characteristics of general shear failure.

- (i) It has well defined failure surfaces, reaching upto ground surface.

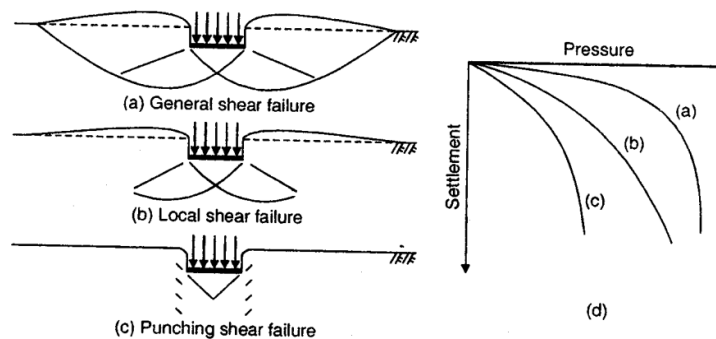

Fig 9.2 Models of Bearing Capacity Failures

- (ii) There is considerable bulging of sheared mass of soil adjacent to the footing.
- (iii) Failure is accompanied by tilting of the footing.
- (iv) Failure is sudden, with pronounced peak resistance.
- (v) The ultimate bearing capacity is well defined.

2. Local shear failure : In local shear failure, there is significant compression of the soil under the footing and only partial development of state of plastic equilibrium. Due to this reason, the failure surfaces do not reach the ground surface and only slight heaving occurs. The pressure settlement curve is represented by curve b of Fig. 24.2(d), where the peak of the base resistance may never be reached. In such a failure, tilting of foundation is not expected. Local shear failure is associated with soils of high compressibility and in sands having relative density lying between 35 and 70 percent. The failure is not sudden, and it is characterized by occurrence of relatively large settlements which would not be acceptable in practice. Also,

ultimate bearing capacity in such a failure is not well defined. Following are typical characteristics of local shear failure.

1. Failure pattern is clearly defined only immediately below the footing.
2. The failure surfaces do not reach ground surface.
3. There is only slight bulging of soil around the footing.
4. Failure is not sudden and there is no tilting of footing.
5. Failure is defined by large settlements.
6. Ultimate bearing capacity is not well defined.

3. Punching shear failure : Punching shear failure occurs where there is relatively high compression of soil under the footing, accompanied by shearing in the vertical direction around the edges of the footing. Punching shear may occur in relatively loose sand with relative density less than 35%. Punching shear failure may also occur in a soil of low compressibility if the foundation is located at considerable depth. The failure surface, which is vertical or slightly inclined and follows the perimeter of the base, never reaches the ground surface. There is no heaving of the ground surface away from the edges and no tilting of the footing. Relatively large settlements occur in this mode. The ultimate bearing capacity is not well defined. Following the characteristics of punching shear failure.

- i) No failure pattern is observed.
- ii) The failure surface, which is vertical or slightly inclined, follows the perimeter of the base.
- iii) There is no bulging of soil around the footing.
- iv) There is no tilting of footing.
- v) Failure is characterized in terms of very large settlements.
- vi) The ultimate bearing capacity is not well defined.

Conditions for typical mode of failure :

Table 9.1 gives the conditions under which a typical mode of failure may occur.

Modes of failure of footings in sand :

Fig. 9.3 shows the modes of failure of footings in sand. As the relative depth / width ratio increases, the limiting relative densities at which failure type change increases.

TABLE 9.1. CONDITIONS OF TYPICAL MODE OF FAILURE

<u>Condition</u>	<u>Mode of failure</u>
1. Footings on ground surface or at shallow depth, in very dense sand	General shear failure
2. Footing on saturated, normally consolidated clay, under undrained loading	General shear failure
3. Very deep footing in dense sand	Punching shear failure
4. Footing on surface or shallow depth in loose sand	Punching shear failure
5. Footing in very dense sand, loaded by transient dynamic loads	Punching shear failure
6. Footing on very dense sand underlain by loose sand or soft clay	Punching shear failure
7. Footing on saturated, normally consolidated clay under drained loading	Punching / local shear failure
8. Footing on ground surface or at shallow depth, in soils of high compressibility	Local shear failure
9. (a) Footing at ground surface or at shallow depth, in sands of relative density between 0.3 to 0.7	Local shear failure
(b) Footing at great depth, in sands of relative density between 0.7 to 0.9	Local shear failure

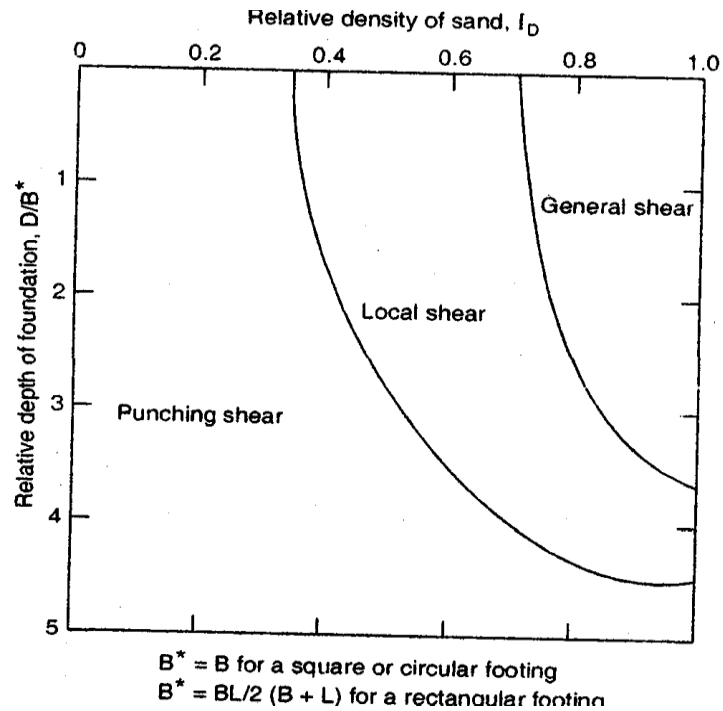

FIG. 9.3 EXPECTED MODES OF FAILURE OF FOOTINGS IN SAND (DE BEER, 1976)

TERZAGHI'S ANALYSIS

An analysis of the condition of complete bearing capacity failure, usually termed general shear failure, can be made by assuming that the soil behaves like an ideally plastic material. The concept was first developed by Prandtl, and later extended by Terzaghi, Meyerhof and others. Terzaghi derived a general bearing capacity equation from a modification of equations proposed by Prandtl. Fig. 9.4 shows a footing of width B , and subjected to loading intensity q_f to cause failure. The footing is shallow, i.e., the depth D of the footing is equal to or less than width B of the footing. Also, the footing is continuous i.e., it is a strip footing ($L > 5B$).

The loaded soil fails along the composite surface $fed_1 f_1$. This region can be divided into five zones : zone I, two pairs of zone II and two pairs of zone III. When the base of the footing ab sinks into the ground, zone I (soil wedge abd) immediately beneath the footing is prevented from undergoing any lateral yield by the friction and adhesion between the soil and the base of

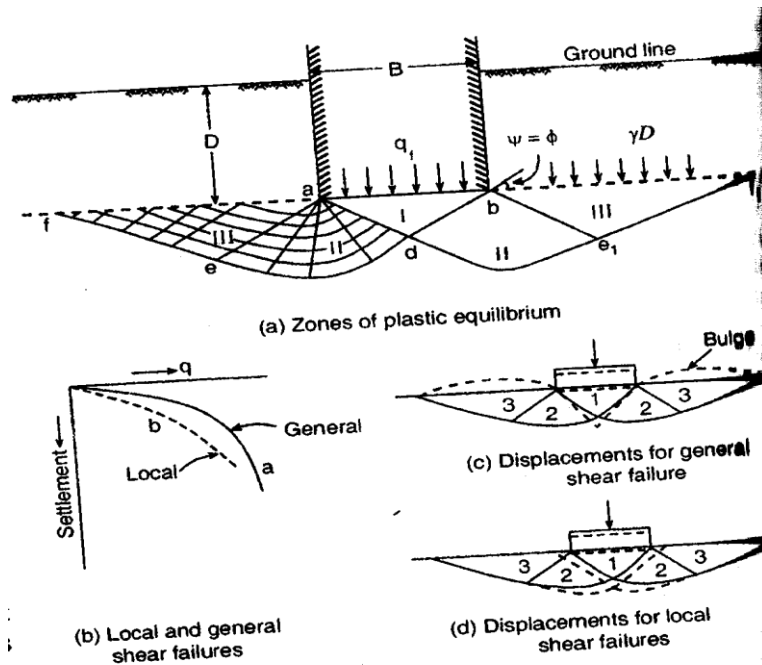

FIG. 24.4. TERZAGHI'S ANALYSIS

FIG. 9.4 TERZAGHI'S ANALYSIS

the footing. Thus, zone I remains in a state of elastic equilibrium, and it acts as if it were part of the footing. Its boundaries ab and da are assumed as plane surfaces, rising at an angle $\psi = \phi$ with the horizontal. Zone II is called the zone of radial shear, as the lines that constitute one set in the shear pattern radiate from the outer edge of the base of the footing. These radial lines are straight while the lines of the other set are the logarithmic spirals with their centres located at the outer edges of the base of the footing. Zone III is called the zone of linear shear, and is identical with the for passive Rankine state. The boundaries of zone III rise at $45^\circ - \phi/2$ with the horizontal. The failure zones are assumed not to extend above the horizontal plane through the base ab of the footing. This implies that the shear resistance of the soil above the horizontal plane through the base of the footing is neglected, and the soil above this plane is replaced with the surcharge $q = \sigma = \gamma D$

The application of the load intensity q_f on the footing tends to push the wedge of the soil abd into

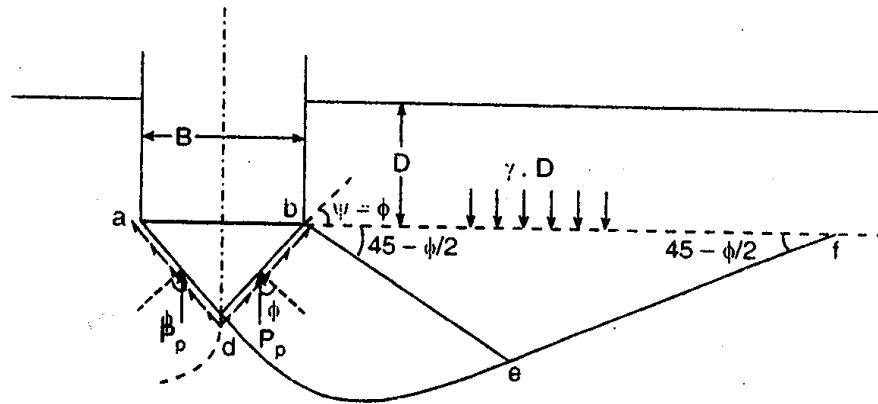

FIG. 24.5. FORCES ACTING TO RESTRAIN FAILURE.

the ground with lateral displacement of zones II and III, but this lateral displacement is resisted by forces on the plane bd and da. These forces are : (i) the resultant of the passive pressure P_p and (ii) the cohesion c acting along the surface da and db. If it is assumed that surfaces db and da intersect the horizontal line at an angle ϕ , the passive pressure acts vertically. At the instant of failure, the downward and upward forces on the edge adb of unit length must balance. The downward forces are (i) $q_f B$ and (ii) the weight $\frac{1}{4}\gamma B^2 \tan \phi$ of the wedge. The upward forces are (i) the resultant passive pressure P_p on each of the surface db and da, and (ii) the vertical component of cohesion acting along the lengths ad and db. The length $db = da = \frac{B/2}{\cos \phi}$ and hence vertical component of cohesion on each of the surface db and

$$da = c \frac{B/2}{\cos \phi} \sin \phi = \frac{B}{2} c \tan \phi$$

Hence

$$q_f + \frac{1}{4}\gamma B \cdot \tan \phi = 2P_p + 2 \cdot \frac{B}{2} c \tan \phi$$

$$q_f B = 2P_p + B \cdot c \tan \phi - \frac{1}{4}\gamma B^2 \tan \phi$$

Or

The resultant of passive earth pressure P_p can be divided into three components : (i) $P_{p\gamma}$ produced by weight of the shear zone dbfe, (ii) P_{pc}

produced by soil cohesion, separately and then added to obtain the value of P_p . Substituting these components in Eq. 24.9, we get.

$$q_f B = 2(P_{p\gamma} + P_{pc} + P_{pq}) + B \cdot c \tan \phi - \frac{1}{4} \gamma B^2 \tan \phi$$

$$q_f B = (2P_{p\gamma} - \frac{1}{4} \gamma B^2 \tan \phi) + (2P_{pc} + B \cdot c \tan \phi) + 2P_{pq} \quad \dots\dots (9.2)$$

Or

Let $2P_{p\gamma} - \frac{1}{4} \gamma B^2 \tan \phi = B \times \gamma N_\gamma$

$$2P_{pc} + B \cdot c \tan \phi = B \times c N_c \quad \text{and} \quad 2P_{pq} = B \times \bar{\sigma} N_q$$

Where $\bar{\sigma}$ = effective over burden pressure above the base of footing.

Substituting in Eq. 9.2 $q_f = cN_c + \bar{\sigma} \cdot N_q + 0.5\gamma BN_\gamma$
 (9.3)

If the water table is below the base of footing, $\bar{\sigma} = \gamma D$ and hence

$$q_f = cN_c + \gamma DN_q + 0.5\gamma BN_\gamma$$

Hence

$$q_{nf} = cN_c + \bar{\sigma} (N_q - 1) + 0.5\gamma BN_\gamma$$

and

$$q_s = \frac{1}{F} [c \cdot N_c + \bar{\sigma} (N_q - 1) + 0.5\gamma BN_\gamma] + \bar{\sigma}$$

If the water table is below the base of footing, the above equations reduce to the forms :

$$q_{nf} = cN_c + \gamma D(N_q - 1) + 0.5\gamma BN_\gamma$$

and

$$q_s = \frac{1}{F} [cN_c + \gamma D(N_q - 1) + 0.5\gamma BN_\gamma] + \gamma D$$

For purely cohesive soil, the bearing capacity is given by

$$q_s = cN_c + \bar{\sigma} N_q = 5.7 c + \bar{\sigma}$$

Where $\bar{\sigma} = \gamma D$ if the water table is below the base of the footing.

Eq. 9.3 is known as Terzaghi's general bearing capacity equation for continuous footing. The parameters N_c , N_q and N_γ are the dimensionless numbers, known as bearing capacity factors depending only on the angle of shearing resistance of the soil. Terzaghi gave the following expressions for the bearing capacity factor :

$$N_q = \frac{a^2}{2 \cos^2(45^\circ + \varphi/2)}, \text{ Where } a = e^{(0.75\pi - \varphi/2)\tan \varphi}$$

$$N_c = (N_q - 1) \cot \varphi$$

and
$$N_\gamma = \frac{\tan \varphi}{2} \left[\frac{K_{py}}{\cos^2 \varphi} - 1 \right]$$

K_{py} = passive earth pressure coefficient, dependent on φ

Terzaghi never explain very well how he obtain K_{py} used to compute N_γ . He did, however, give a curve of φ versus N_γ and three specific values of N_γ at $\varphi = 0, 34^\circ$ and 48° . The values of the bearing capacity factors N_q , N_c and N_γ can be obtained from Table 9.2. The values of N_γ for φ of 34° and 48° are the original Terzaghi values which were used by Bowles to back compute K_{py} . The back compound values of K_{py} are also given in Table 9.2.

General and local shear failure : The type of failure analyzed above is called the general shear failure, and the bearing capacity factor N_q , N_c and N_γ correspond to the general shear failure. In such a failure, the soil properties are assumed to be such that a slight downward movement of footing develops fully plastic zones and the soil bulges out. In the case of fairly soft or loose and compressible soil, large deformations may occur below the footing before the failure zones are fully developed. Such a failure is called a local shear failure. Which is associated with considerable vertical soil movement before soil bulging takes place. In the absence of analytical solution, Terzaghi has proposed the following local shear- failure soil parameters.

$$C_m = \frac{2}{3} c$$

$$\tan \varphi_m = \frac{2}{3} \tan \varphi$$

The bearing capacity factors are determined with respect to these reduced parameters C_m and ϕ_m . The bearing capacity factors corresponding to the local shear failure are indicated with dashes N_q' and N_y' and the bearing capacity equation (Eq. 9.3) reduces.

to

$$q_f = \frac{2}{3}c \cdot N_c + \bar{\sigma} N_q + 0.5\gamma B N_y'$$

It is difficult to define the limiting conditions for which general or local shear failure should be assumed at a given site. However, the following points may be used as a guide:

(i) Stress strain test (c- ϕ soil) : General shear failure at low strain, say < 5%, while for local shear failure, stress strain curve continues to raise at strains of 10 to 20%

(ii) Angle of shear resistance : For $\phi > 36^\circ$, general shear failure
 $\phi > 36^\circ$, local shear failure.

(iii) Penetration test : $N \geq 30$: General shear failure
 $N \leq 5$: Local shear failure

(iv) Plate load test : Shape of the load settlement curve decides whether it is general shear failure or local shear failure.

(v) Density Index : $I_D > 70$: General shear failure
 $I_D < 20$: Local shear failure

For purely cohesive soil, local shear failure may be assumed to occur when the soil is soft to medium, with an unconfined compressive strength $q_u \leq 100 \text{ KN/m}^2$

or $C_u \leq \text{KN/m}^2$.

FIG. 9.2 TERZAGHI'S BEARING CAPACITY FACTORS

ϕ	<i>General shear failure</i>			<i>Local shear failure</i>		
	N_c	N_q	N_γ	N'_c	N'_q	N'_γ
0	5.7*	1.0	0.0	5.7	1.0	0.0
5	7.3	1.6	0.5	6.7	1.4	0.2
10	9.6	2.7	1.2	8.0	1.9	0.5
15	12.9	4.4	2.5	9.7	2.7	0.9
20	17.7	7.4	5.0	11.8	3.9	1.7
25	25.1	12.7	9.7	14.8	5.6	3.2
30	37.2	22.5	19.7	19.0	8.3	5.7
34	52.6	36.5	35.0	23.7	11.7	9.0
35	57.8	41.4	42.4	25.2	12.6	10.1
40	95.7	81.3	100.4	34.9	20.5	18.8
45	172.3	173.3	297.5	51.2	35.1	37.7
48	258.3	287.9	780.1	66.8	50.5	60.4
50	347.5	415.1	1153.2	81.3	65.6	87.1

* = $(1.5 \pi + 1)$

Assumptions in Terzaghi's Analysis :

1. The soil is homogenous and isotropic and its shear strength is represented by Comomb's equation.
2. The strip footing has a rough base, and the problem is essentially two dimensional.
3. The elastic zone has straight boundaries inclined at $\phi = \theta$ to the horizontal and the plastic zones fully develop.
4. P_p consists of three components which can be calculated separately and added although the critical surface for these components are not identical.
5. Failure zones do not extend above the base is neglected and the effect of soil around the footing is considered equivalent to a surcharge $= \sigma = \gamma D$.

Limitations : (1) As the soil compresses, ϕ changes; slight downward movement of footing may not develop fully the plastic zones. (2) Error due to assumption 4 is small and on the safe side (3) Error due to assumption 5 increases with depth of foundation, and hence the theory is suitable for shallow foundation only.

Specialization of Terzaghi's equations :

In order to take into account the shape of the footing (i.e. strip, round, square etc.), Terzaghi used only shape factors with cohesion (s_c) and base (s_y) terms. Taking into account these factors, Terzaghi's original equation (Eq. 24.12) can be expressed as under :

$$q_f = C N_c S_c + \bar{\sigma} N_q + 0.5\gamma B N_\gamma S_\gamma$$

The values of s_c and s_y are given below.

Shape	Strip	Round	Square	Rectangle
s_c	1.0	1.3	1.3	$1 + 0. B/L$
s_y	1.0	0.6	0.8	0.8 or $1 - 0.3 B/L$

Based on these values, Terzaghi gave the following semi-empirical equations for square, circular and rectangular footings :

(a) Frictional cohesive soil ($c - \phi$ soil)

For circular footing : $q_f = 1.3 cN_c + \bar{\sigma} \cdot N_q + 0.3 \gamma B N_\gamma$

Where B = diameter of the footing.

For square footing: $q_f = 1.3 cN_c + \bar{\sigma} \cdot N_q + 0.4 \gamma B N_\gamma$

Where B = width (or length of footing)

For rectangular footing $q_f = cN_c \left(1 + 0.3 \frac{B}{L}\right) + \bar{\sigma} \cdot N_q + 0.4 \gamma B N_\gamma$

Alternatively, $q_f = cN_c \left(1 + 0.3 \frac{B}{L}\right) + \bar{\sigma} \cdot N_q + 0.5 \gamma B N_\gamma \left(1 - 0.2 \frac{B}{L}\right)$

(b) Cohesive soil ($c = \phi ; c > 0$)

For circular footing $q_f = 1.3 cN_c + \bar{\sigma} = 7.4 + \bar{\sigma}$

This considerably greater than the value of $q_f = 5.7 + \bar{\sigma}$ for strip footing.

For rectangular and square footing :

$$q_f = cN_c \left(1 + 0.3 \frac{B}{L}\right) + \bar{\sigma}$$

(c) Non-cohesive soil ($\phi = c ; 0 > c$)

For strip footing : $q_f = \bar{\sigma} N_q + 0.5 \gamma B N_\gamma$

For rectangular and square footing :

$$q_f = \bar{\sigma} N_q + 0.4 \gamma B N_\gamma$$

$$q_f = \bar{\sigma} N_q + 0.3 \gamma B N_\gamma$$

I.S. CODE METHOD FOR COMPUTING BEARING CAPACITY:

1. General : IS code (IS : 6403-1981), recommends a bearing capacity equation which is similar in nature to those given by Meyerhof and Brinch Hansen. The code recognizes, depending upon the deformations associated with the load and the extent of development of failure surface, three types of failures of soil support beneath the foundations, They are : (a) general shear failure ; (b) local shear failure ; and (c) Punching shear failure. The first two types of failures have already been described. The punching shear failure, occurs on soils of high compressibility. In such failure, there is vertical shear around the footing, perimeter and compression of soil immediately under the footing, with soil on the sides of the footing remaining practically un-involved.

2. Bearing capacity equation for strip footing for c- ϕ soils. : The ultimate net bearing capacity of strip footing is given by the following equations:

(i) For the case of general shear failure :

$$q_{nf} = cN_c + \bar{\sigma} (N_q - 1) \frac{1}{2} B \gamma N_\gamma$$

(ii) For the case of local shear failure :

$$q_{nf} = \frac{2}{3} cN_c + \bar{\sigma} (N_q' - 1) \frac{1}{2} B \gamma N_\gamma$$

Where $\bar{\sigma}$ = effective surcharge at the base level of foundation.

N_c, N_q, N_γ = Bearing capacity factors.

These factors are computed from the followings equations.

$$N_c = (N_q - 1) \cot \phi$$

$$N_c = \tan^2 \left(45^\circ + \frac{\phi}{2} \right) e^{\pi \tan \phi} \quad \text{and} \quad N_\gamma = 2(N_q +$$

1) $\tan \phi$(Vesic)

These factors are given in Table 9.3, for various values of ϕ at 1° interval. Original Table by IS : 6403 – 1981 give these values at 5° interval of ϕ .

TABLE 9.3 BEARING CAPACITY FACTORS (IS : 6403-1981)

ϕ°	N_c	N_q	N_γ	ϕ°	N_c	N_q	N_γ
0	5.14	1.00	0.00				
1	5.38	1.09	0.07	26	22.25	11.85	12.54
2	5.63	1.20	0.15	27	23.94	13.20	14.47
3	5.90	1.31	0.24	28	25.80	14.72	16.72
4	6.19	1.43	0.34	29	27.86	16.44	19.34
5	6.49	1.57	0.45	30	30.14	18.40	22.40
6	6.81	1.72	0.57	31	32.67	20.63	25.99
7	7.16	1.88	0.71	32	35.49	23.18	30.22
8	7.53	2.06	0.86	33	38.64	26.09	35.19
9	7.92	2.25	1.03	34	42.16	29.44	41.06
10	8.35	2.47	1.22	35	46.12	33.30	48.03
11	8.80	2.71	1.44	36	50.59	37.75	56.31
12	9.28	2.97	1.69	37	55.63	42.92	66.19
13	9.81	3.26	1.97	38	61.35	48.93	78.03
14	10.37	3.59	2.29	39	67.77	55.96	92.25
15	10.98	3.94	2.65	40	75.31	64.20	109.41
16	11.63	4.34	3.06	41	83.86	73.90	130.22
17	12.34	4.77	3.53	42	93.71	85.38	155.55
18	13.10	5.26	4.07	43	105.11	99.02	186.54
19	13.93	5.80	4.68	44	118.37	115.31	224.64
20	14.83	6.40	5.39	45	133.88	134.88	271.76
21	15.82	7.07	6.20	46	152.10	158.51	330.35
22	16.88	7.82	7.13	47	173.64	187.21	403.67
23	18.05	8.66	8.20	48	199.26	222.31	496.01
24	19.32	9.60	9.44	49	229.93	265.51	613.16
25	20.72	10.66	10.88	50	266.89	319.07	762.89

For obtaining N_c, N_q, N_γ corresponding to local shear failure, calculate $\phi' = \tan^{-1}(0.67 \phi)$ and read N_c, N_q and N_γ from Table 24.9 corresponding to the value of ϕ' instead of ϕ .

3. **Shape factor, depth factor and inclination factor** : The above bearing capacity equations, applicable for strip footing, shall be modified to take into account, the shape of the footing, inclination of loading, depth of embedment and effect of water table. The modified bearing capacity formulae are given below :

(i) For general shear failure

$$q_{nf} = cN_c \cdot s_c \cdot d_c \cdot i_c + \bar{\sigma} (N_q - 1) s_q \cdot d_q \cdot i_q \text{ By } N_\gamma \cdot s_\gamma \cdot d_\gamma \cdot i_\gamma w'$$

(ii) For local shear failure

$$q_{nf} = \frac{2}{3} c N_c \cdot s_c \cdot d_c \cdot i_c + \bar{\sigma} (N_q - 1) s_q \cdot d_q \cdot i_q + \frac{1}{2} B \cdot \gamma \cdot N_\gamma \cdot s_\gamma \cdot d_\gamma \cdot i_\gamma \cdot W'$$

The shape factors s_c , s_q and s_γ are given in table 24.10.

The depth factors are given as under :

$$d_c = 1 + 0.2 \frac{D}{B} \cdot \sqrt{N_c}$$

$$d_q = d_\gamma = 1 \text{ for } \phi < 10^\circ$$

$$d_q = d_\gamma = 1 + 0.1 \frac{D}{B} \sqrt{N_q} \text{ for } \phi > 10^\circ \text{ where } N_\phi = \tan^2(45^\circ + \phi/2)$$

Table 9.4 shape factors (IS : 6403-1981)

Shape of base	Shape factors		
	s_c	s_q	s_γ
1. Continuous strip	1.0	1.0	1.0
2. Rectangle	$(1 + 0.2 \frac{B}{L})$	$(1 + 0.2 \frac{B}{L})$	$(1 - 0.4 \frac{B}{L})$
3. Square	1.3	1.2	0.8
4. Circle	1.3	1.2	0.6

Note. In case of circular footing, use B as the diameter.

The depth factors are to be applied only when the back filling is done with proper compaction. The inclination factors are given as under :

$$i_c = i_q = (1 - \frac{\alpha}{90})^2 \quad \text{and} \quad i_\gamma = (1 - \frac{\alpha}{90})^2$$

Where α = inclination of the load to the vertical, in degrees,

4. Effect of water table : The effect of water table is taken into account in the form of a correction factor W' applied to the 'wedge term' in Eqs. 24.41 and 24.42. The value of W' may be chosen as indicated below :

(a) If the water table is likely to permanently remain at or below a depth of $(D+B)$ beneath the ground level surrounding the footing, then $W'=1$

(b) If the water table is located at a depth D or likely to rise to the base of footing or above, then the value of W' shall be taken as 0.5.

(c) If the water table is likely to permanently get located at depth $D < D_w < (D+B)$, the W' be obtained by linear interpolation. Thus, for the intermediate case, we get the following expression for W' .

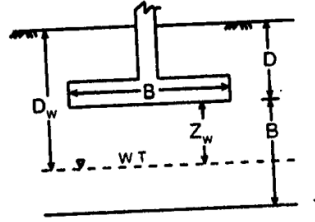

FIG. 9.6 EFFECT OF WATER TABLE

$$W' = 0.5 \left[1 + \frac{D_w - D}{B} \right] = 0.5 \left[1 + \frac{Z_w}{B} \right]$$

When $Z_w = 0$, $W' = 0.5$, when $Z_w = B$, $W' = 1$

The validity of the above equation is within the range $D < D_w < (D+B)$. If we compare the above expression with Eq. 24.36, it is clear that W' is same as factor R_{w2} .

It may be noted that if the water table rises above the base of footing, W' will remain at its minimum value of 0.5, but $\bar{\sigma}$ (effective overburden pressure) will be computed of the basis of total unit weight of the portion of soil above the water table and submerged unit weight for the portion below the water table.

5. Cohesionless soils ($c=0$) : for cohesionless soils, having $c = 0$, Indian standard code recommends that the bearing capacity be calculated (a) based on relative density or (b) based on standard penetration resistance value, and (c) based on static cone penetration test.

(a) Based on relative density : In this method, bearing capacity may be calculated by, together with relevant shear strength parameter. In these formulae, c is taken equal to zero. The relative density given in Table 9.5 is used as a guide to determine the method of analysis.

TABLE 9.5 METHOD OF ANALYSIS BASED ON RELATIVE DENSITY

Relative density (Density Index)	Voids Ratio	Condition	Method of analysis
1. Greater than 70%	Less than 0.5	Dense	General shear
2. Less than 20%	Greater than 0.75	Loose	Local shear (as well as punching shear)
3. 20% to 70%	0.55 to 0.75	Medium	Interpolate between (1) and (2)

(b) Based on standard penetration resistance value : The standard penetration resistance (24.14) is determined at a number of selected points at intervals of 75 cm in the vertical direction or change of strata if it takes place earlier and the average value beneath each point is determined between the level of base of the footing and the depth equal to 1.5 to 2 times the width of foundation. In computing the value, any individual value more than 50 percent of the average calculate shall be neglected and average recalculated (the values for all loose seams shall however be included).

Knowing the value of N, the value of ϕ is read from fig. The ultimate net bearing capacity is then calculated from the formula :

$$q_{nf} = \bar{\sigma}(N_q - 1) S_q + d_q + i_q + \frac{1}{2} \gamma B N_\gamma \cdot s_\gamma \cdot d_\gamma \cdot i_\gamma \cdot W'$$

Where the shape factors, depth factors and inclination factors are determined as described earlier, and the bearing capacity factors N_q and N_γ are taken from Table 9.2.

(c) Based on state cone penetration test : The static cone point resistance q_c is determined as per IS: 4968 (Part – III) – 1976 at a number of selected points at intervals of 10 to 15 cm. The observed values are corrected for the dead weight of sounding rods. Then the average value at each one of the location is determined between the level of the base of the footing and the depth equal to $1\frac{1}{2}$ to 2 times the width of the footing. The determined for each one of the location and the minimum of the average value is used in the design.

The net ultimate bearing capacity is shallow strip footing on cohesionless soil deposit is then determined from Fig.

6. Cohesive soils : ($\phi = 0$) : The net ultimate bearing capacity immediately after construction on fairly saturated homogenous cohesive soils can be calculated from the expression :

$$q_{nf} = cN_c \cdot s_c \cdot d_c \cdot i_c$$

Where $N_c = 5.14$ (for $\phi = 0$)

The value of c is obtained from unconfined compressive strength test. Alternatively, cohesion c may be determined from the static cone point resistance q_c using the empirical relationship given in Table.

Table 9.6 (Relationship between q_c and c)

Soil Type	Point Resistance Value Q_c (kgf /cm ²)	Range of undrained cohesion (kgf /cm ²)
1. Normally consolidated clays	$q_c < 20$	$\frac{q_c}{18}$ to $\frac{q_c}{15}$
2. Over consolidated clays	$q_c > 20$	$\frac{q_c}{26}$ to $\frac{q_c}{22}$

Note. 1 Kgf / Cm² = 100 kN /m²

Example 9.1. A square footing 2.5 m by 2.5 m is built in a homogenous bed of sand of unit weight 20 kN/m³ and having an angle of shearing resistance of 36°. The depth of the base of footing is 1.5 m below the ground surface. Calculate the safe load that can be carried by a footing with a factor of safety of 3 against complete shear failure. Use Terzaghi's analysis.

Solution . Given : $B = 2.5$ m ; $D = 1.5$ m ; $\gamma = 20$ kN / m³. Since the soil is dense, and $\phi = 36^\circ$, the footing is likely to fail by general shear failure.

From table the values of bearing capacity factors are :

$$N_c = 65.4, N_q = 49.4 \text{ and } N_\gamma = 54.0 \quad \text{Also, } \bar{\sigma} = \gamma D$$

Since $c = 0$, $q_f = \gamma D N_q + 0.4 \gamma B N_\gamma$

$$\text{Or } q_{nf} = \gamma D (N_q - 1) + 0.4 \gamma B N_\gamma = 20 \times 1.5 (49.4 - 1) + 0.4 \times 20 \times 2.5 \times 54.0$$

$$= 1452 + 1080 = 2532 \text{ kN/m}^2$$

$$\therefore q_s = \frac{q_{nf}}{F} + \gamma D \text{ (Eq. 24.14)} = \frac{2532}{3} + (20 \times 1.5) = 844 + 30 =$$

$$874 \text{ kN/m}^2$$

$$\text{Maximum safe load} = B^2 \times q_s = (2.5)^2 \times 874 = 5462.5 \text{ kN}$$

Example 9.2 : What will be the maximum safe load for example 9.1 if the soil is loose sand of unit weight 16 kN/m^3 and the angle of shearing resistance is 25° .

Solution : Since the soil is loose and $\phi = 28^\circ$, the footing is likely to fail by local shear failure. From Table, for $\phi = 25^\circ$.

$$N_q' = 5.6 \text{ and } N_y' = 3.2$$

$$q_{nf} = \gamma D(N_q - 1) + 0.4\gamma B N_y' = 16 \times 1.5 (5.6 - 1) + 0.4 \times 16 \times 2.5 \times 3.2$$

$$= 110.4 + 51.2 = 161.6 \text{ kN/m}^2$$

$$q_s = \frac{q_{nf}}{F} + \gamma D = \frac{161.6}{3} + (16 \times 1.5) = 77.87 \text{ kN/m}^2$$

$$\therefore \text{ Safe load} = B^2 \times q_s = (2.5)^2 (77.87) = 846.7 \text{ kN.}$$

Example : 9.3 A strip footing, 1 m wide at its base is located at a depth of 0.8 m below the ground surface. The properties of the foundation soil are : $\gamma=15 \text{ kN/m}^3$, $c= 30 \text{ kN/m}^2$ and $\phi = 20^\circ$. Determine the safe bearing capacity, using a factor of safety of 3. Use Terzaghi's analysis. Assume that the soil fails by local shear.

Solution : The bearing capacity is given by, taking $\bar{\sigma} = \gamma D$

$$q_f = \frac{2}{3} c N_c' + \gamma D N_q' + 0.5\gamma B N_y'$$

For $\phi = 20^\circ$, the bearing capacity factors taken from Table are :

$$N_c' = 11.8 ; N_q' = 3.9 ; N_y' = 1.7$$

$$q_f = \left(\frac{1}{2} \times 30 \times 11.8\right) + (18 \times 0.8 \times 3.9) + (0.5 \times 18 \times 1 \times 1.7)$$

$$= 236 + 56.2 + 15.3 = 307.5 \text{ kN/m}^2$$

$$q_{nf} = q_f - \gamma D = 307.5 - 18 \times 0.8 = 293.1 \text{ kN/m}^2$$

$$q_s = \frac{q_{nf}}{F} + \gamma D = \frac{293.1}{3} + (18 \times 0.8) = 112.1 \text{ kN/m}^2$$

9.3 MACHINE FOUNDATION

Introduction to Soil Dynamics :

Soil dynamics is defined as that constituent part of soil mechanics which deals with soil under dynamic conditions. It studies the effect of forces on soil in any way associated with causing motions in soil as well as with the mutual dynamic interaction of the foundation and soil (Jumikis, 1969). Most of the motions encountered in soil dynamics work are those of vibration, plane linear motion, motion brought about by impact shock elastic waves; and seismic action of geophysical forces.

The design of foundations of turbines, motors, generators compressors, forge hammers and other machines, having a rhythmic application of unbalanced forces require special knowledge of theory of harmonic vibrations. Inertial forces of rotating elements of machines contribute, besides their static loads, additional dynamic loads. The machinery vibration influences adversely the foundation supporting soil by densifying it which may in turn, cause differential settlement of soil and foundation.

Terms associated with soil dynamics

Vibrations:- If the motion of the body is oscillatory in character, it is called vibrations.

Degrees of Freedom:- The number of independent which are required to define the position of a system during vibration, is called degrees of freedom (Fig.).

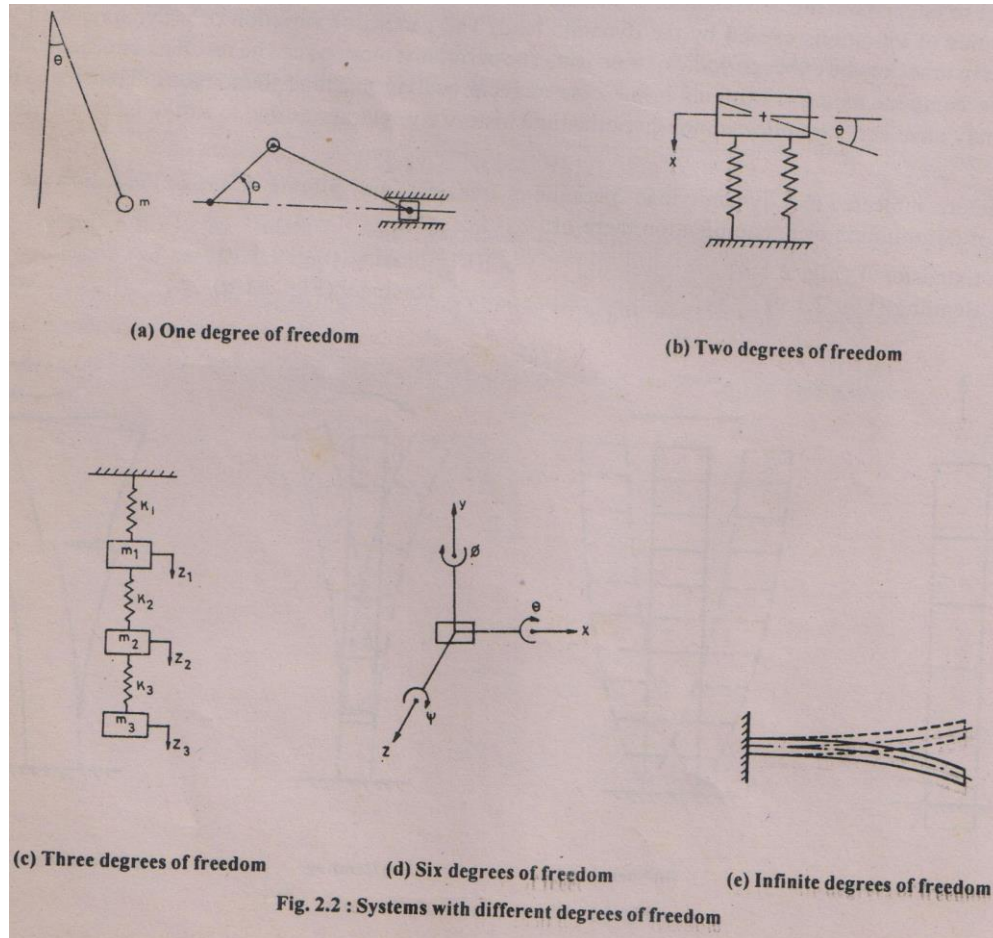

Periodic Motion:- If motion repeats itself at regular intervals of time, it is called periodic motion.

Free Vibration:- If a system vibrates without an external force, then it is said to undergo free vibrations. Such vibrations can be caused by setting the system in motion initially and allowing it to move freely afterwards.

Natural Frequency:- This is the property of the system and corresponds to the number of free oscillations made by the system in unit time.

Forced Vibrations:- Vibrations that are developed by externally applied forces are called forced vibrations. These vibrations occur at the frequency of the externally applied exciting force.

Forcing Frequency:- This refers to the periodicity of the external forces which acts on the system during forced vibration. This is also termed as operating frequency.

Frequency Ratio:- The ratio of the forcing frequency and natural frequency of the system is referred as frequency ratio.

Amplitude of Motion:- The maximum displacement of a vibrating body from the mean position is amplitude of motion.

Time Period:- Time taken to complete one cycle of vibration is known as time period.

Resonance:- A system having n degrees of freedom has n natural frequencies. If the frequency of excitation coincides with any one of the natural frequencies of the system, the condition of resonance occurs. The amplitudes of motion are very excessive at resonance.

Damping:- All vibration system offer resistance to motion due to their own inherent properties. This resistance is called damping force and it depends on the condition of vibration, material and type of the system. If the force of damping is constant, it is termed Coulomb damping. If the damping force is proportional to the velocity, it is termed viscous damping. If the damping in a system is free from its material property and is contributed by the geometry of the system, it is called geometrical or radiation damping.

Principal Modes of Vibration:- In a principal mode, each point in the system vibrates with the same frequency. A system with n degrees of freedom possess n principal modes with n natural frequencies.

Normal Mode of Vibration:- If the amplitude of a point of the system vibrating in one of the principal modes is made equal to unity, the motion is then called the normal mode of vibration.

The mass spring system :

In soil dynamics problems, the analysis may be conveniently carried out by a single equivalent mass supported by a perfectly elastic system – the soil being replaced by the spring Fig. shows mass-spring system (or spring mass system), in which the weight $W=mg$ may be associated with the weight of the vibrating vibrator or foundations. The elastic spring represents the real the real soil support. Such a system has six degrees of freedom, and has thus six natural frequencies.

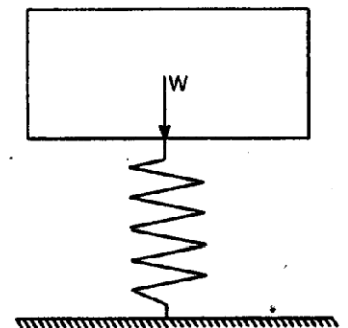

Free-Vibrations. Let the mass spring system be set to vibration by an external force which is then removed. The system will continue to oscillate indefinitely with the same frequency and amplitude if external force or internal friction is absent. The time for one complete oscillation of the mass is called

the free period and distance up or down from the equilibrium position is called the amplitude.

Fig. shows a simple spring with a spring constant k kg/m. When a weight W is attached to it (without any vibrations), it extends by an amount δ_s [Fig. 28.2 (b)]

$$\delta_s = \frac{W}{k}$$

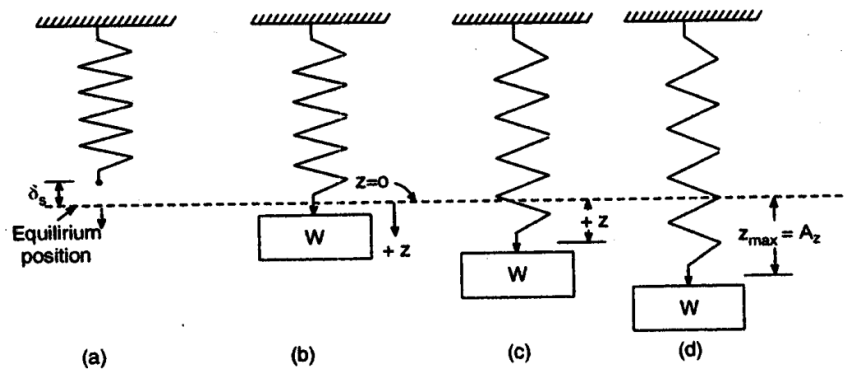

If the spring mass system is pulled down, by an external force, by a maximum distance Z_{max} or A_z (called the amplitude), and then released, the whole system vibrates with a certain frequency. Let z be the displacement of the mass at any instant, with respect to the equilibrium position, the force F_s is the spring (\uparrow) is then given by

$$F_s = k(\delta_s + z) = k\delta_s + kz = W + kz$$

The force acts in the opposite direction to the motion at any instant. The gravity force W acts downward. Hence when the motion is downward, the net downward force is equal to $W \downarrow - (W + kz) \uparrow$. This must be equal to mass \times acceleration. Hence, we get

$$W - (W + kz) = \frac{W}{g} \frac{d^2z}{dt^2}$$

Or
$$\frac{W}{g} \frac{d^2z}{dt^2} + kz = 0$$

Which is usually written as
$$mz + kz = 0$$

Where $m =$ mass of the vibrating body $= W/g$

$z = \text{acceleration}$

Eq. is called the equation of motion, which is similar to the following standard equation of motion :

$$z + \omega_n^2 z = 0$$

Where $\omega_n = \text{natural frequency of the system.}$

Comparing Eqs.,

$$\omega_n^2 = \frac{k}{m}$$

Or

$$\omega_n = \sqrt{\frac{k}{m}} = \sqrt{\frac{kg}{W}} \text{ rad / sec}$$

If f_n is the natural frequency of the system in cycles per second, we have

$$f_n = \frac{\omega_n}{2\pi} =$$

$$\frac{1}{2\pi} \sqrt{\frac{kg}{W}} \text{ cycles / sec}$$

28.3 Vibrating spring – mass system with damping

:

If the spring mass system be provided with dash-pot, having c as the damping factor and z is the velocity of the vibration system at any instant, the force in the dash-pot, opposite the motion, will be equation to cz .

Hence the equation of the motion will be

$$W \downarrow - (W + kz) \uparrow = cz \uparrow = mz$$

$$mz + cz + kz = 0$$

Coming this with the standard equation for damping vibrations :

$$z + 2nz + \omega_n^2 z = 0$$

We get

$$n = \frac{c}{2m}$$

Or

$$\omega_n = \sqrt{\frac{k}{m}}$$

Eq. is the standard differential equation which can be solved by putting

$$z = C'e^{-t} \dots (i)$$

$$z = C'\lambda e^{-t} \dots \dots (ii)$$

$$z = C'\lambda^2 . e^{-t} \dots \dots \dots (iii)$$

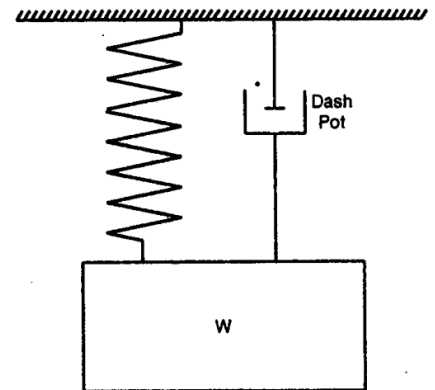

FIG. 28.3. VIBRATING SPRING-MASS SYSTEM WITH DAMPING

Putting these in Eq., we get

$$mC'^2 e^{-2t} + cC'e^{-t} + kC'e^{-t} = 0$$

$$\lambda = -\frac{c}{2m} \pm \sqrt{\left(\frac{c}{2m}\right)^2 - \left(\frac{k}{m}\right)} = -n \pm \sqrt{n^2 - \omega_n^2}$$

Hence $\lambda_1 = -n + \sqrt{n^2 - \omega_n^2}$ and $\lambda_2 = -n - \sqrt{n^2 - \omega_n^2}$

Three cases may arise from Eq. :

Case (i) Real, if $n^2 > \omega_n^2$

Case (ii) Zero, if $n^2 = \omega_n^2$

Case (iii) Imaginary or complex if $n^2 < \omega_n^2$

Case (ii) Gives a value of $\lambda = -n = -\frac{c}{m} = \sqrt{\frac{k}{m}}$

Eq. for case (ii) to $e^{-t} = 0$, indicating that for this condition there will be no oscillation, but only a rapid return back to the equilibrium position of the mass [Fig. 28.4 (b)]. The value of c for this condition is called critical damping c_c .

$$C_c = 2m\sqrt{\frac{k}{m}} = 2\sqrt{mk}$$

For case, (i), the radical is real ($n^2 > \omega_n^2$), and $c \geq 2\sqrt{mk}$.

Hence from (i), $z = C'e^{-t} = c'e \left\{ -\frac{c}{2m} \pm \sqrt{\left(\frac{c}{2m}\right)^2 - \frac{k}{m}} \right\} t$

Eq. shows that z is not a periodic function of time. Therefore, the motion, when $n^2 - \omega_n^2 > 0$ is a vibration, because it can only approach the equilibrium position at $t \rightarrow \infty$. However, the viscous resistance is so pronounced that the weight set in motion from its equilibrium does not vibrate but creeps gradually back to the equilibrium position at time infinity
For case (iii) when $n^2 < \omega_n^2$,

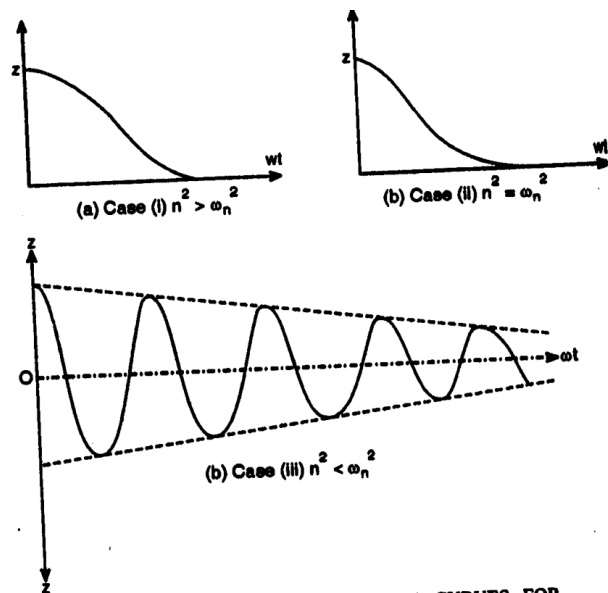

FIG. 28.4. TIME DISPLACEMENT CURVES FOR DAMPED VIBRATIONS.

$$\omega_d^2 = \omega_n^2 - n^2 \text{ is positive or } c < 2\sqrt{mk}$$

Let λ_1 and λ_2 be the two roots of Eq. :

$$\lambda_1 = -n + \omega_d i$$

Now Eq. gives two particular solutions of Eq. Also, the sum of difference of these two solutions multiplied by any constant is also a solution :

$$\therefore z_1 = \frac{C_1}{2} (e^{-1.t} - e^{-2.t})$$

$$\text{And } z_2 = \frac{C_2}{2} (e^{-1.t} - e^{-2.t})$$

Where C_1 and C_2 are constants.

Substituting the values of λ_1 and λ_2 from Eq. and simplifying, we get

$$z_1 = C_1 e^{-nt} \sin \omega_d t \quad \text{and} \quad z_2 = C_2 e^{-nt} \cos \omega_d t$$

Summation of $z_1 + z_2 = z$ renders the general solution of Eq. in the following form.

$$z = e^{-nt} [C_1 \sin \omega_d t + C_2 \cos \omega_d t]$$

The quantity in the bracket presents the simple harmonic motion of the case of vibration without damping while e^{-nt} is the damping term fig. shows the time displacement curve for this case. The period T of the damping vibration is given by

$$T = \frac{2\pi}{\omega_d} = \frac{2\pi}{\sqrt{\omega^2 - n^2}}$$

The term ω_d is called the frequency of damped vibrations.

$$\omega_d = \sqrt{\omega^2 - n^2} = \sqrt{\frac{k}{m} - \frac{c^2}{4m^2}}$$

Or

$$\omega_d = \sqrt{\frac{k}{m}} \sqrt{1 - \frac{c^2}{4km}} = \omega_n \sqrt{1 - \left(\frac{c}{C_c}\right)^2}$$

Forced vibrations :

Forced vibrations of a system are generated and sustained by the application of an external periodic movement of the foundation of the system. Forced vibrations constitute the most important type of vibration in machine

foundation design. We shall consider the case of forced vibrations with damping. Generally, for oscillating machinery (where the machinery vibrates because an unbalanced rotational force exists), the force can be expressed as a sine or cosine function, such as $F_0 \sin \omega t$. The equation of motion for such a case may be written as :

$$m\ddot{z} + c\dot{z} + kz = F_0 \sin \omega t$$

or

$$\ddot{z} + \frac{c}{m}\dot{z} + \frac{k}{m}z = \frac{F_0}{m}\sin \omega t$$

The solution of the above equation may be assumed in the following forms :

$$z = A \cos \omega t + B \sin \omega t$$

By successive differentiation, we obtain

$$\dot{z} = -A\omega \sin \omega t + B\omega \cos \omega t$$

$$\ddot{z} = -A\omega^2 \cos \omega t - B\omega^2 \sin \omega t$$

Substituting into (a), we get.

$$(-A\omega^2 \cos \omega t - B\omega^2 \sin \omega t) + \frac{c}{m}(-A\omega \sin \omega t + B\omega \cos \omega t) + \frac{k}{m}(A \cos \omega t + B \sin \omega t) = \frac{F_0}{m} \sin \omega t$$

Equating the co-efficient of $\sin \omega t$ to both sides,

$$-B\omega^2 - \frac{c}{m}A\omega + \frac{k}{m}B = \frac{F_0}{m}$$

Similarly, equating the coefficients of $\cos \omega t$ to both sides,

$$-A\omega^2 - \frac{c}{m}B\omega + \frac{k}{m}A = 0$$

Solving Eqs. 28.22 (a) and (b) for coefficients A & B, we get

$$A = -\frac{F_0 c \omega}{(k - m\omega^2)^2 + (c\omega)^2} \quad B = -\frac{F_0(m\omega^2 - k)}{(k - m\omega^2)^2 + (c\omega)^2}$$

Substituting these in Eq. we get the solution in the form

$$z = \frac{F_0 - c\omega}{(c\omega)^2 + (k - m\omega^2)^2} \cos \omega t + \frac{F_0(k - m\omega^2)}{(c\omega)^2 + (k - m\omega^2)^2} \sin \omega t$$

The equation represents the components due to forced vibrations with the period of $T = \frac{2\pi}{\omega}$. The frequency of vibrations (in cycles per second) is given by

$$f = \frac{\omega}{2\pi}$$

The frequency of vibration, as defined earlier, is given by

$$\omega_n = \sqrt{\frac{k}{m}} \text{ radians /sec}$$

and

$$f_n = \frac{\omega_n}{2\pi} = \frac{1}{2\pi} \sqrt{\frac{k}{m}}$$

Substituting in

$$\frac{-F_0 c \omega}{(c\omega)^2 + (k - m\omega^2)^2} = z_2 \sin \phi \quad \text{and} \quad \frac{-F_0 (k - m\omega^2)}{(c\omega)^2 + (k - m\omega^2)^2} = z_2 \cos \phi$$

We get
$$z = z_2 (\sin \phi \cos \omega t + \cos \phi \sin \omega t) = z_2 \sin(\omega t + \phi)$$

Where the angle ϕ is termed as the phase represent a pair of vectors which must be added to obtain the displacement, the solution for the displacement due to the forced vibrations of Eq. 28.24 becomes.

$$z = \sqrt{A^2 + B^2} F_0 \sin(\omega t + \phi)$$

Substituting the values of A and B, and noting from Eq. 28.12 that

$$c = 2\sqrt{mk} = 2k\sqrt{\frac{m}{k}} = \frac{2k}{\omega_n} \quad \text{or} \quad k = \frac{\omega_n c}{2}$$

We get
$$z = \frac{F_0}{k} \frac{1}{\sqrt{\left(\frac{2c\omega}{\omega_n}\right)^2 + \left[1 - \left(\frac{\omega}{\omega_n}\right)^2\right]^2}} \sin(\omega t + \phi)$$

Or
$$z = \frac{F_0}{k} \frac{\sin(\omega t + \phi)}{\sqrt{\left(2\frac{c}{\omega_n} \frac{f}{f_n}\right)^2 + \left[1 - \left(\frac{f}{f_n}\right)^2\right]^2}}$$

The maximum deflection z_{\max} is thus given by

$$z_{\max} = A_z = \frac{\frac{F_0}{k}}{\sqrt{\left(2\frac{c}{c_c} \cdot \frac{f}{f_n}\right)^2 + \left[1 - \left(\frac{f}{f_n}\right)^2\right]^2}}$$

$$\frac{F_0}{k} = \delta_s = \text{static deflection of spring}$$

But

$$\therefore \frac{A_z}{\delta_s} = \frac{z_{\max}}{\delta_s} = \frac{1}{\sqrt{\left(2\frac{c}{c_c} \cdot \frac{f}{f_n}\right)^2 + \left[1 - \left(\frac{f}{f_n}\right)^2\right]^2}}$$

Where $A_z = z_{\max}$ = maximum dynamic deflection of the system.

Putting $\frac{A_z}{\delta_s} = \frac{z_{\max}}{\delta_s} = \mu$ = magnification factor or dynamic amplification factor

$$\frac{\omega}{\omega_n} = \frac{f}{f_n} = r = \text{frequency ratio} \quad \text{and} \quad \frac{c}{c_c} = \mathcal{E} = \text{damping ratio}, \quad \text{we get}$$

$$\mu = \frac{1}{\sqrt{(1 - r^2)^2 + 4\mathcal{E}^2 r^2}}$$

Fig. 28.5 shows a plot between the magnification factor and the frequency ratio $r (= \frac{f}{f_n} = \frac{\omega}{\omega_n})$ for various of damping ratio $\mathcal{E} (= \frac{c}{c_c})$.

From Fig., it is observed that magnification factor suddenly shoots up for the values of r between 0.6 to 1.5. At $r = 1$, resonance occurs for an undamped conditions, the magnification factor (and hence the amplitude) is maximum at $r < 1$. Thus, these curves show the effect of damping on shifting the frequency for maximum amplification away from the natural foundation frequency. The aim of the designer should be such that the frequency ratio $\frac{f}{f_n}$ is either less than 0.6 or more than 1.5. However, the frequency f of the machine is always constant, and a foundation engineer has to manipulate the natural frequency f_n of the machine foundation system by suitably proportioning it.

Transmitted force (F_T)

In a damped forced vibratory system, the support is derived from the foundation by way of transmitting a force (F_T) to the foundation. This transmitted force (F_T) can be expressed as $F_T = c \frac{dz}{dt} + k z$

From Eq. 28.30 b.

$$z = \frac{F_0}{k} \frac{\sin(\omega t + \varphi)}{\sqrt{(2 \frac{c}{c_c} \frac{f}{f_n})^2 + \{1 - (\frac{f}{f_n})^2\}^2}}$$

$$\frac{F_0}{k} \frac{\sin(\omega t + \varphi)}{\sqrt{4E^2 r^2 + (1-r^2)^2}}$$

Or $z = \frac{F_0}{k} \mu \sin(\omega t + \varphi)$

Where $\mu = \frac{1}{\sqrt{4E^2 r^2 + (1-r^2)^2}} =$
magnification factor

Substituting this value of z in Eq, we get

$$F = c \frac{d}{dt} \left[\left(\frac{F_0}{k} \mu \right) \sin(\omega t + \varphi) \right] + k \left(\frac{F_0}{k} \mu \right) \sin(\omega t + \varphi)$$

or $F_T = c \frac{F_0 \mu}{k} \cos(\omega t + \varphi) \omega + k \left(\frac{F_0 \mu}{k} \right) \sin(\omega t + \varphi)$

or $F_T = \left(c \frac{F_0 \mu}{k} \right) \sqrt{c^2 \omega^2 + k^2} [\cos(\omega t + \varphi - \beta)]$ where $\beta = \tan^{-1} \frac{k}{c \omega}$

Hence the magnitude of the force F_T is given by

$$|F_T| = \left(\frac{F_0 \mu}{k} \right) \sqrt{k^2 + c^2 \omega^2} = F_0 \mu \sqrt{1 + \frac{c^2 \omega^2}{k^2}}$$

But $k = \frac{\omega_n c_c}{2}$ from Eq. 28.29 (μ)

Hence, from 3, $F_T = F_0 \mu \sqrt{1 + 4 \frac{\omega^2}{\omega_n^2} \cdot \frac{c^2}{c_c^2}}$; $F_T = F_0 \mu \sqrt{1 + 4 r^2 E^2}$

Also ratio $\frac{F_T}{F_0} = T = \mu \sqrt{1 + 4 r^2 E^2} =$ Force transmissibility

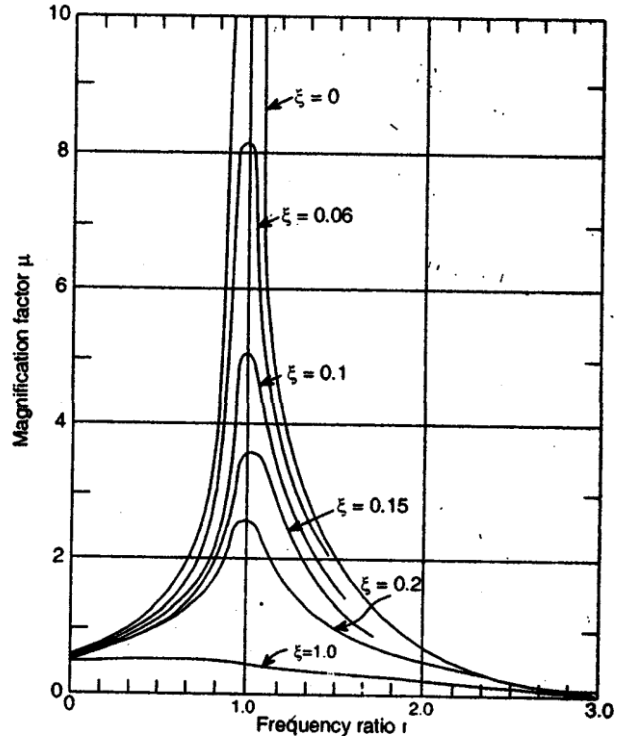

FIG. AMPLITUDE FREQUENCY RELATIONSHIP FOR DAMPED FORCED VIBRATIONS.

Natural frequency of foundation soil system :

In the previous discussion, we have used the term m as the mass of the vibration system. This includes the mass of a certain volume soil co-vibration with the system. The mass of co-vibrating soil is called the apparent soil mass, participating in the vibrations.

Thus, $m = m_v + m_s$

Where m_v = mass of the vibrator

m_s = apparent soil mass (mass of the co-vibrating soil)

$$\omega_n = \sqrt{\frac{k}{m_v + m_s}} = \sqrt{\frac{kg}{w_v + w_s}}$$

Or

$$f_n = \frac{1}{2\pi} \sqrt{\frac{k}{m_v + m_s}} = \frac{1}{2\pi} \sqrt{\frac{kg}{w_v + w_s}}$$

Where W_v = Weight of the vibrator, and

W_s = Weight of the apparent soil mass.

Unfortunately, the size of the co-vibrating body of soil cannot be determined exactly as yet because it depends on frequency and is influenced by the size of the base area of the vibrator (foundation) and by the elastic properties of the soil (spacing).

We shall consider here three methods of determining the natural frequency of foundation soil system : (1) Barken's method (2) Balakrishna Rao's, (3) Pauw's method.

BARKEN' METHOD

Barken suggested the following equation for the natural frequency of system.

$$w_n = \sqrt{\frac{C_u A}{m}}$$

Where C_u = Co-efficient of elastic uniform compression of soil

A = contact area of foundation with soil

m = mass of machine plus foundation

The amplitude of displacement is given by

$$A_z = \frac{F}{m\omega n^2(1-r^2)}$$

Where $A_z = z_{\max}$ = maximum displacement

F_0 = exciting force : r = frequency ratio $\frac{\omega}{\omega_n}$

The above formulae for natural frequency takes no account of the mass of soil vibrating with the foundations.

Barken gave the following equation for the co-efficient of elastic uniform compression of soil, obtained from the solution of theory of elasticity problem concerning the distribution of normal stresses under the base contact area of a rigid plate :

$$C_u = 1.13 \frac{E}{1 - \mu^2} \frac{1}{\sqrt{A}}$$

Where E = Young's modulus of soil ; μ = Poisson's ratio

Thus, C_u depends not only on elastic constants E and μ changes in inverse proportion to the square root of the base area of the foundation :

$$\frac{C_{u2}}{C_{u1}} = \sqrt{\frac{A_1}{A_2}}$$

Table gives the recommended value of C_u for $A = 10 \text{ m}^2$, for various soils.

TABLE 28.1. RECOMMENDED DESIGN VALUES OF THE CO-EFFICIENT OF ELASTIC UNIFORM COMPRESSION C_u (BARKEN, 1962)

Soil group category	Soil group	Permissible load on soil under action of static load only (kg/cm²)	Coefficient of elastic uniform compression C_u (kg/m²)
I	Weak soils (clays and silty clays with sand, in a plastic state, clayey, and silty sands; also soils of categories II and III with laminae of organic silt and of peat)	up to 1.5	up to 3
II	Soil of medium strength (clays and silty clays with sand, close to the plastic limit; sand)	1.5—3.5	3—5
III	Strong soils (clays and silty clays with sands of hard consistency; gravels and gravelly sand, loess and loessial soils)	3.5—5	5—10
IV	Rocks	Greater than 5	Greater than 10

GENERAL PRINCIPLES OF MACHINE FOUNDATION DESIGN

General :-

For machine foundations which are subjected to dynamic loads in additions to static loads, the conventional considerations of bearing capacity and allowable settlement are insufficient to ensure a safe design. In general, a foundation weighs several times as much as machine (Cozens, 1938; Rausch, 1959). Also the dynamic loads produced by the moving parts of the machine are small in comparison to the static weight of the machine and foundation. But the dynamic load acts respectively on the foundation soil system over long periods of time. Therefore, it is necessary that the soil behaviour be elastic under the vibration levels produced by the machine, otherwise deformation will increase with each cycle of loading and excessive settlement may occur. The most important parameters of the design of a machine foundation are : (i) natural frequency of the machine-foundation-soil system; and (ii) amplitude of motion of the machine at its operating frequency.

Types of Machine and Foundations:-

There are various types of machines that generate different periodic forces. The main categories are:

Reciprocating Machines: These includes steam, diesel and gas engines, compressor and pumps. The basic mechanism of a reciprocating machine consists of a piston that moves within a cylinder, a connecting rod, a piston rod and a crank. The crank rotates with a constant angular velocity. Figure 10.1 shows the outline of a typical Gangsaw in which the out of balances forces may lead to vibration problems.

The operating speeds of reciprocating machines are usually smaller than 1000rpm. Large reciprocating engines, compressors and blowers generally operate at frequencies ranging within 50-250rpm. Reciprocating engines such as diesel and gas engines operate within 300-1000rpm.

The magnitude of the unbalanced forces and moments depend upon the number of cylinder in the machine, their size, piston displacement and the direction of mounting. The mechanism developing out of balance inertia forces for a single crank is shown in Fig. 10.2. It consists of a piston of mass m_p moving within a cylinder, a connecting rod AB of mass m_r and crank AO of mass m_c which rotates about point O at a frequency w . The centre of gravity of the connecting rod is located at a distance L_1 from point A. If the rotating masses are to be

partially or fully balanced, counterweights of mass m_w may be located with their centre of gravity at point C.

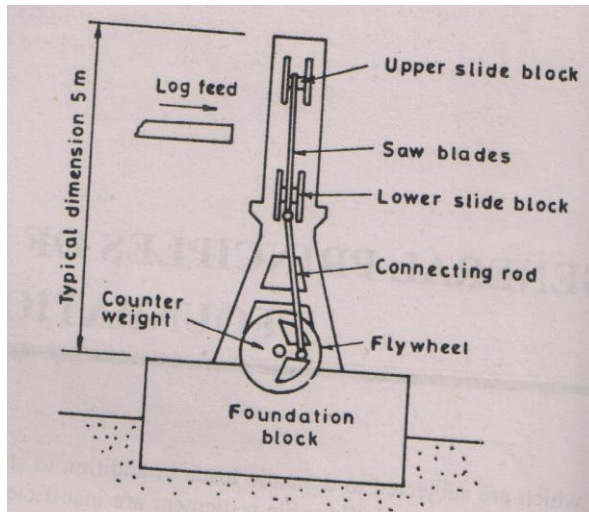

Fig. 10.1 : Outline of a typical Gang-saw machine

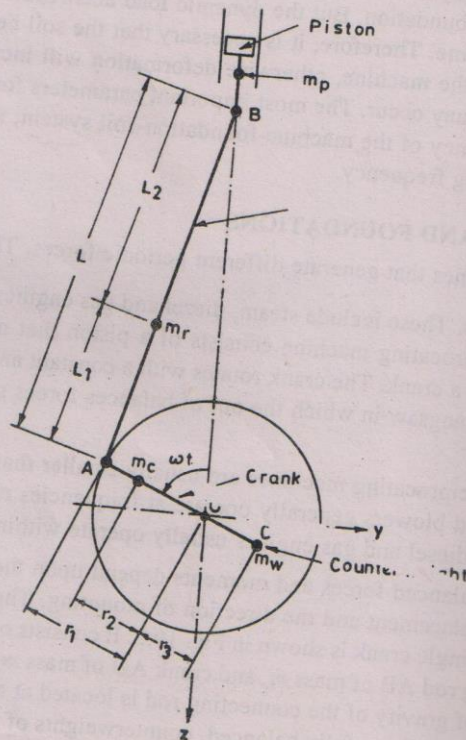

Fig. 10.2 : Crank mechanism

In order to simplify the analysis of the motion of the connecting rod, the mass m_r is replaced by two equivalent masses; one rotating with the crank pin A, the other translating

with the wrist pin B. The inertia forces can then be expressed in terms of the total rotating mass (m_{rot}) and the total reciprocating mass (m_{rec}). The total rotating mass is assumed to be concentrated at the crank pin A.

$$m_{rot} = \frac{r_2}{r_1} m_c + \frac{L_2}{L} m_r - \frac{r_3}{r_1} m_w$$

$$m_{rec} = m_a + \frac{L_1}{L} m_r$$

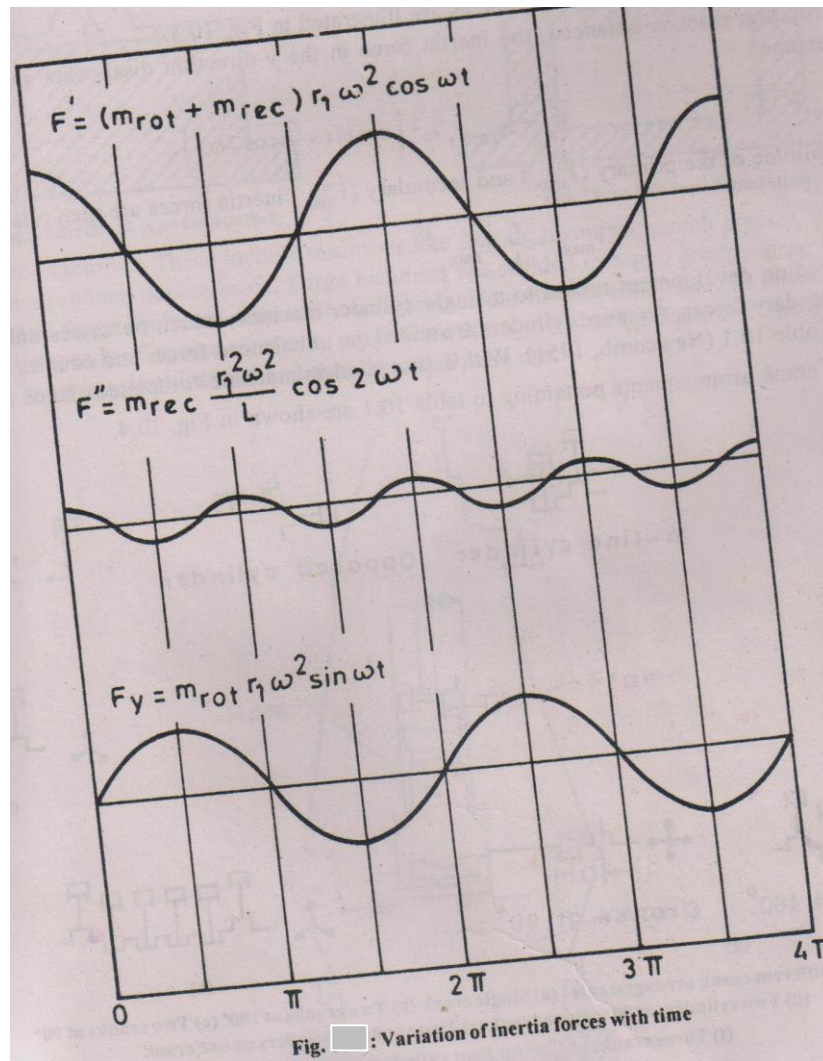

The inertia force (F_z) in the z direction may be shown to be

$$F_z = (m_{rot} + m_{rec}) r_1 \omega^2 \cos \omega t + m_{rec} \frac{r_1^2}{L} \omega^2 \cos 2 \omega t$$

which has a primary component (F) acting at the frequency of rotation, and a secondary component (F'') acting at twice the rotation frequency.

$$F_z = F' + F''$$

And in the y direction

$$F_y = m_{rot} \cdot r_1 \omega^2 \sin \omega t$$

The time variations of these inertia forces are illustrated in Fig. 10.3

If the rotating mass is balanced, the inertia force in the y direction disappears and that in the z direction becomes

$$F_z = m_{rec} \cdot r_1 \omega^2 (\cos \omega t + \frac{r_1}{L} \cos 2 \omega t)$$

The amplitude of the primary (F'_{max}) and secondary (F''_{max}) inertia forces are then related as follows

$$F''_{max} = \frac{r_1}{L} F'_{max}$$

The preceding development relates to a single cylinder machine, which possess unbalanced primary and secondary forces. As more cylinders are added the unbalanced forces and couples are modified as shown in Table 10.1 (Newcomb, 1951). With a six cylinders machine complete balance is achieved.

Different crank arrangements pertaining to table are shown in Fig.

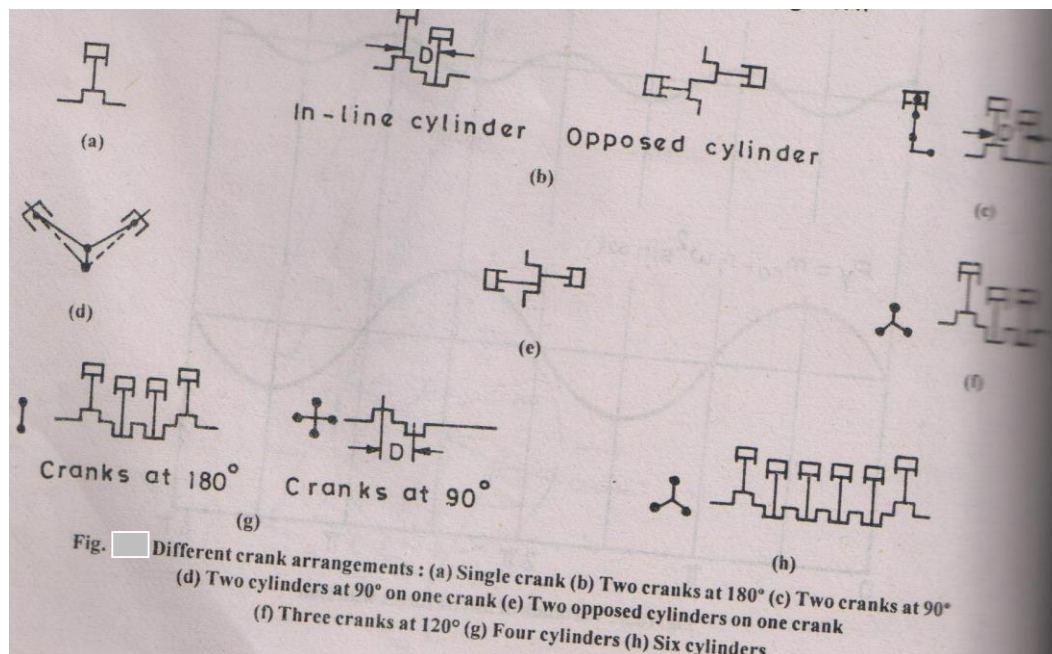

Reciprocating machines are very frequently encountered in practice. Usually the following two types of foundations are used for such machines.

- (a) Block type foundation consisting of a pedestal of concrete on which the machine rests.
- (b) Box or Caisson type foundation consisting a hollow concrete block supporting the machinery on its top.

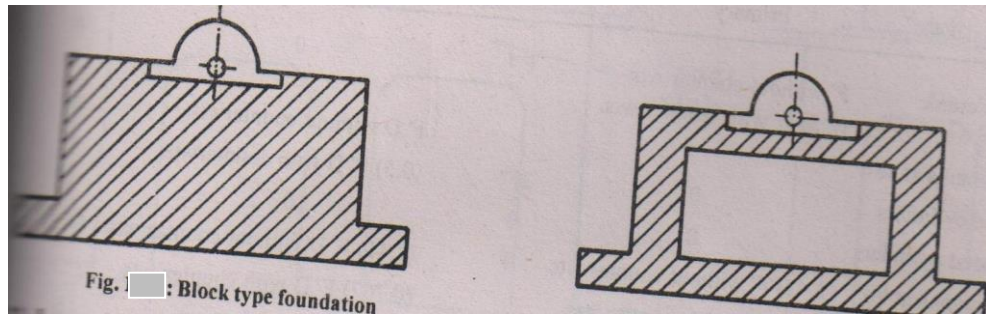

Impact Machines:- These include machines like forging hammer, punch presses and stamping machines which produce impact loads. Forge hammers are divided into two groups: drop hammers for die stamping and forge hammers proper. These machines consist of falling ram, an anvil, and a frame. The speeds of operation usually range from 50 to 150 blows per minute. The dynamic loads attain a peak in a very short interval and then practically die out.

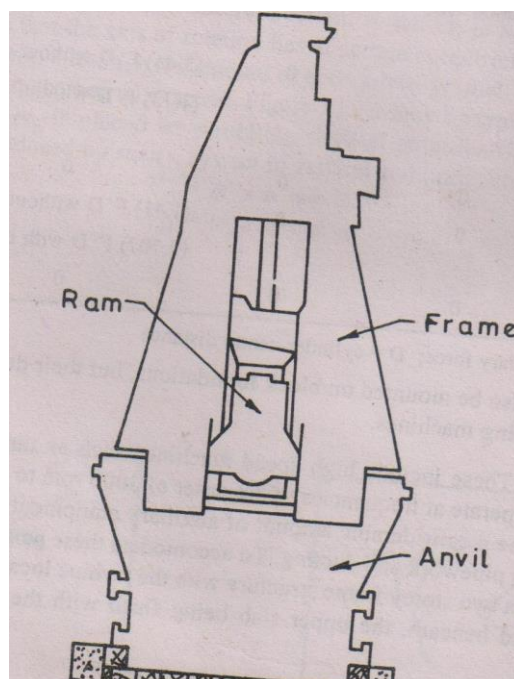

Table - Unbalanced Forces and Couples for Different Crank Arrangement (Newcomb, 1951)

	Crank Arrangement	Forces		Couples	
		Primary	Secondary	Primary	Secondary
	Fig. 10.4				
a.	Single crank	F' without counter wts. (0.5) F' with wts	F''	0	0
b.	Two cranks 180° In-line cylinders opposed cylinders	0 0	2F'' 0	F'D without counter wts. (0.5) F'D with counter wts. 0	0 0 0
c.	Two cranks at 90°	(1.41)F' without counter wts. (0.707) F' with couter wts.	0	(1.41)F'D without counter wts. (0.707)F'D with counter wts.	F''D
d.	Two cylinder on one crank, cylinder at 90°	F' without counter wts. 0 with counter wts.	1.41 F''	0	0
e.	Two cylinder on one crank, opposed cylinders	2F' without counter wts. F' with counter wts.	0	0	0
f.	Three cranks at 120°	0	0	(3.46)F'D without counter wts. (1.73)F'D without counter wts.	(3.46)F'' D
g.	Four cylinders cranks at 180° crank at 90°	0 0	0 0	0 (1.41)F'D without counter wts. (0.707)F'D with counter wts	(4.0)F'' D
h.	Six cylinders	0	0	0	0

F' = primary force; F'' = secondary forces; D = cylinder-centre distance

Impact machines may also be mounted on block foundations, but their details would be quite different from these of reciprocating machines.

Rotary Machines:- These include high speed machines such as turbo generators, turbines and rotary compressors which operates at frequencies of the order of 3000rpm to 10000rpm. Associated with these machines there may be a considerable amount of auxiliary equipment such as condensers, coolers and pumps with connecting pipework and ducting. To accommodate these auxiliary equipments a common foundation arrangement is a two storey frame structure with the turbine located on the upper slab and the auxiliary equipment placed beneath, the upper slab being flush with the floor level of machine hall.

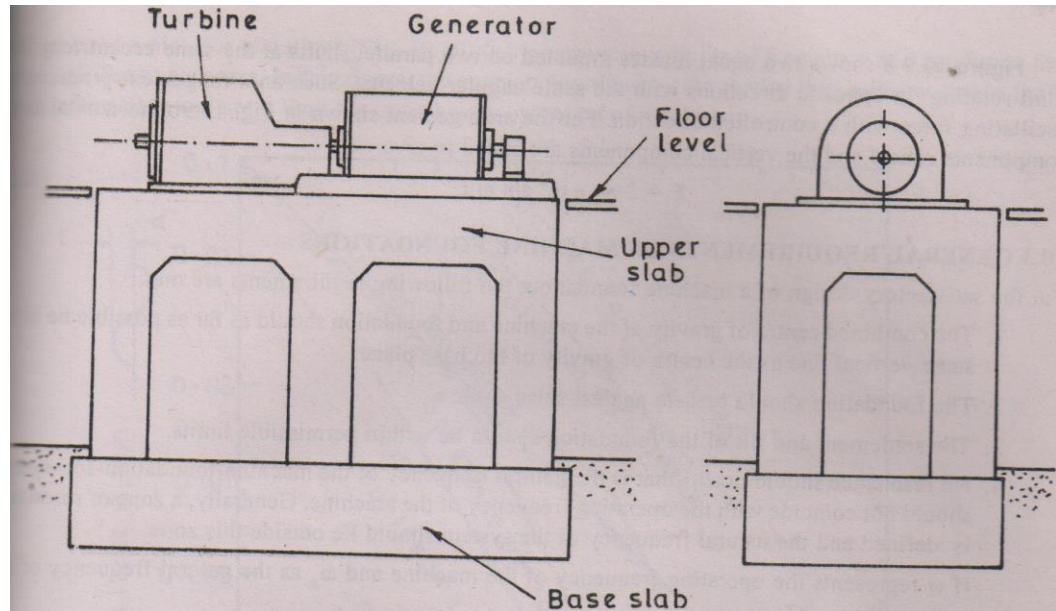

Rotating machinery is balanced before erection. However, in actual operation some inbalance always exists. It means that the axis of rotation lies at certain eccentricity with respect to principal axis of inertia of the whole unit. Although the amount of eccentricity is small in rotary machines the unbalanced which a single mass m_e is placed on a rotating shaft at an eccentricity e from axis of rotating. The unbalanced forces produced by such a system in vertical and horizontal directions are given by

$$F_V = m_e e \omega^2 \sin \omega t$$

$$F_H = m_e e \omega^2 \cos \omega t$$

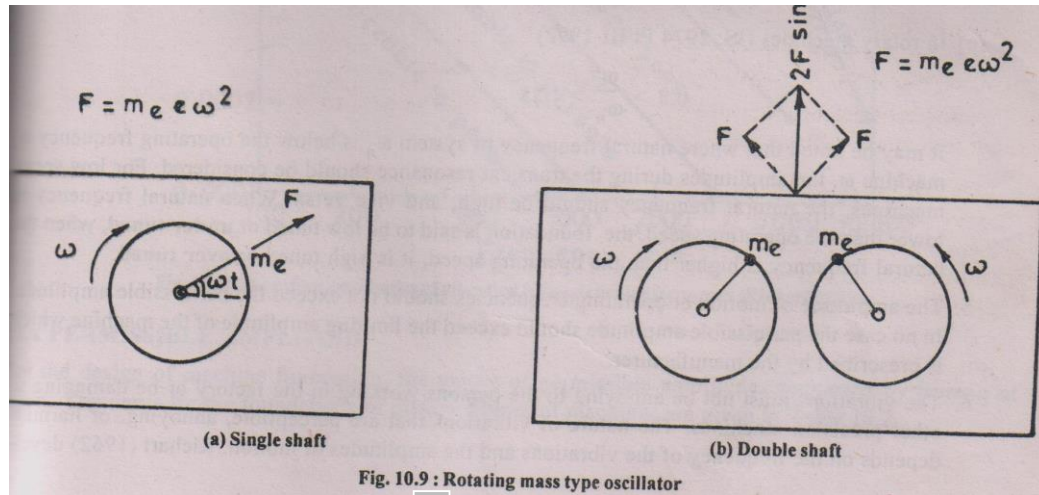

Fig. 10.9 : Rotating mass type oscillator

Figure. shows two equal masses mounted on two parallel shafts at the same eccentricity, the shaft rotating in opposite directions with the same angular velocity. Such an arrangement produces an oscillating force with a controlled direction. For the arrangement shown in Fig. 10.9b, horizontal force components cancel and the vertical components are added to give

$$F = 2 m_e e \omega^2 \sin \omega t$$

10.3 General Requirements of Machine Foundations:- For the satisfactory design of a machine foundation, the following requirements are met:

1. The combined centre of gravity of the machine and foundation should as far as possible be in the same vertical line as the centre of gravity of the base plane.
2. The foundation should be safe against shear failure.
3. The settlement and tilt of the foundation should be within permissible limits.
4. No resonance should occur; that is the natural frequency of the machine-foundation-soil system should not coincide with the operating frequency of the machine. Generally, a zone of resonance is defined and the natural frequency of the system should lie outside this zone.

If w represents the operating frequency of the machine and w_n as the natural frequency of the system, then

- a) In reciprocating machines (IS : 2974 pt I-1982)

For important machines : $0.5 > \frac{w}{w_n} > 2.0$

For ordinary machines: $0.6 > \frac{w}{w_n} > 1.5$

b) In impact machines (IS : 2974 Pt II-1980)

$$0.4 > \frac{w}{w_n} > 1.5$$

c) (IS : 2974 Pt III-1992)

$$0.8 > \frac{w}{w_n} > 1.25$$

It may be noted that where frequency of system w_n is below the operating frequency of machine w , the amplitudes during the transient resonance should be considered. For low speed machines, the natural frequency should be high, and vice versa. When natural frequency is lower than the operating speed, the foundation is said to be low tuned or under tuned, when the natural frequency is higher than the operating speed, it is high tuned or over tuned.

5. The amplitude of motion at operating frequencies should not exceed the permissible amplitude. In no case the permissible amplitude should exceed the limiting amplitude of the machine which is prescribed by the manufacturer.
6. The vibrations must not be annoying to the persons working in the factory or the damaging to other precision machines. The nature of vibrations that are perceptible, annoying or harmful depends on the frequency of the vibrations and the amplitudes of motion. Richart (1962) developed a plot for vibrations that gives various limits of frequency and amplitude for different purpose. In this figure, the envelop described by the shaded line indicates only a limit for safety and not a limit for satisfactory operation of machines.

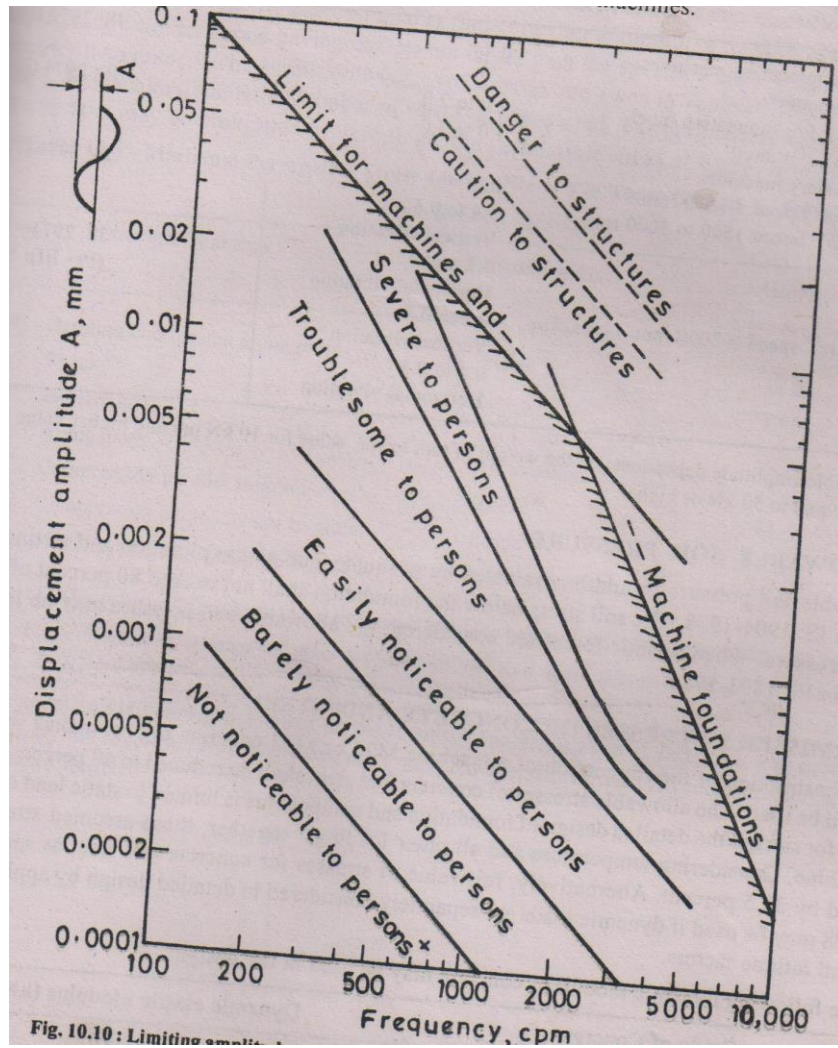

Permissible Amplitude:-

For the design of machine foundation, the values of permissible amplitudes suggested by Bureau of Indian Standards for the foundations of different types of machines are given in Table.

Table Value of permissible amplitude for foundations of different machines:-

Sl. No.	Type of machine	Permissible amplitude mm	Reference
1.	Reciprocating machines	0.2	IS: 2974 (Pt-I)
2.	Hammer*		
	a) For foundation block	1.0 to 2.0	IS : 2974 (Pt-II)
	b) For anvil	1.0 to 3.0	
3.	Rotary machines		
	a) Speed < 1500rpm	0.2	IS : 2974 (Pt-IV)
	b) Speed 1500 to 3000rpm	0.4 to 0.6	
		Vertical vibration	
		0.7 to 0.9	
		Horizontal vibration	
	c) Speed > 300rpm	0.2 to 0.3	
		Vertical vibration	
		0.4 to 0.5	
		Horizontal vibration	

Permissible amplitude depends on the weight of tup, lower value for 10kN tup and higher value for the tup weight equal to 30kN or higher.

Allowable Soil Pressure:-

The allowable soil pressure should be evaluated by adequate sub-soil exploration and testing in accordance with IS: 1904-1978. The soil stress below the foundation shall not exceed 80 percent of the allowable soil pressure. When seismic forces are considered, the allowable soil pressure may be increased as specified in IS: 1893-1984.

Permissible Stresses of Concrete and Steel:-

For the construction of the foundation of a machine M20 or M25 concrete in accordance with IS: 456-1978 shall be used. The allowable stresses of concrete and steel shall be reduced to 40 percent for concrete and 55% for steel, if the detailed design for foundation and components is limited to static load of foundation and machine. Considering temperature and all other loadings together, these assumed stresses may be exceeded by

33.5 percent. Alternately, full value of stresses for concrete and steel as specified in IS: 456-1978 may be used if dynamic loads are separately considered in detailed design by applying suitable creep and fatigue factors.

The following dynamic moduli of concrete may be used in the design:

Grade of concrete	Dynamic elastic modulus (kN/m ²)
M20	3.0x10 ⁷
M25	3.4x10 ⁷
M30	3.7x10 ⁷

Permissible Stresses of Timber:-

The timber is generally used under the anvil of hammer foundation. Grade of timber is specified according to the size of defects like knots, checks etc. in the timber. Timber is thus classified into three grades select, Grade I and Grade II. The best quality timber having minimum or no defects at all is of the select grade. Grade I timber is one having defects not larger than the specified ones. Grade II timber is poorer in quality than grade I. The permissible values of stresses are given in Table for species of timber of grade I. In machine foundations timber of select grade is used. The permissible stresses of timber given in Table may be multiplied by 1.16 to get the permissible stresses of timber of select grade.

Table Minimum permissible stress limits (N/mm²) in three groups of structural timbers (For grade I Material)

Sl. No.	Strength character	Location of use	Group A	Group B	Group C
i.	Bending and tension	Inside ⁽²⁾	18.0	12.0	8.5
ii.	along grain		1.05	0.64	0.49
iii.	Shear ⁽¹⁾	All locations	11.7	7.8	4.9
iv.	Horizontal	All locations	4.0	2.5	1.1
v.	Along grain	Inside ⁽²⁾	12.6	9.8	5.6
	Compression parallel to grain	Inside ⁽²⁾			
	Compression perpendicular to grain	All locations and grade			
	Modulus of elasticity (x 10 ³ N/mm ²)				

- (i) The values of horizontal shear to be used only for beams. In all other cases shear along grain to be used.
- (ii) For working stresses for other locations of use, that is out side and wet, generally factors of 5/6 and 2/3 are applied.

The permissible bearing pressures on other elastic materials such as felt, cork and rubber are generally given by the manufactureres of these materials. No specific values are recommended here since then vary in wide limits.

FOUNDATIONS OF ROTARY MACHINES

General:-

The unprecedented burden cast by the importance to oil can be relived only by exploiting indigenous energy resources efficiently. Major power energy resource, in long term power plan, incorporate an optimal mix of thermal, hydel and nuclera generation. Power intensity is relatively high in our country due to various reasons including the substantial substitution among the forms of energy in the various important sectors along with the accelerated programme in rural electrification and assured power supply for agriculture sector etc. The aim of planning to generate power higher than the demand by at

least 10 percent, calls for a coordinated development of the power supply industry. As per the present ratio, the thermal sector caters 54 percent; hydro sector 43 percent and 3 percent catered by nuclear sector. The 15 year National Power Plan from 1980 onwards envisages the installation of additional generating capacity of almost 100,000 MW in the thermal, hydro and nuclear sectors taken together as against the existing generation capacity of 31,000MW. Large capacity thermal power station at coal pit heads called Super Thermal Power stations (2000MW capacity or more) because of their size and sophisticated technology, will account for as much as 50,000 MW to be commissioned during the next five year plan.

The turbogenerator unit is most expensive, vital and important part in a thermal power plant. The operating speeds of turbogenerators may range from 3000rpm to 10000rpm. Auxiliary equipments such as condenser, heat exchanger, pipe lines, air vents and ducts for electric wiring are essential features of a turbogenerator installation. Frame foundations are commonly used for turbogenerators with four reason:

- a) auxiliary equipment can be arranged more conveniently,
- b) the inspection of and access to all parts of the machine become more convenient,
- c) less liable to cracking due to settlement and temperature changes, and
- d) more economical due to the saving in material and freedom to add more members to stiffen if needed.

The frame foundation is the assemblage of columns, longitudinal and transverse beam. The transverse beams may be often eccentric with respect to the column centre lines and generally have varying cross-section due to several opening in the top deck and haunches at the junction with columns. The isometric view of a typical frame foundation is shown in Fig.

In a power-plant, the long term satisfactory performance of the turbogenerators is affected by their foundation, hence there is vital need to adequately design these foundations for all possible combinations of static and dynamic loads. Interaction with the mechanical engineer is also required for any adjustment in the layout of machinery and auxiliary fittings.

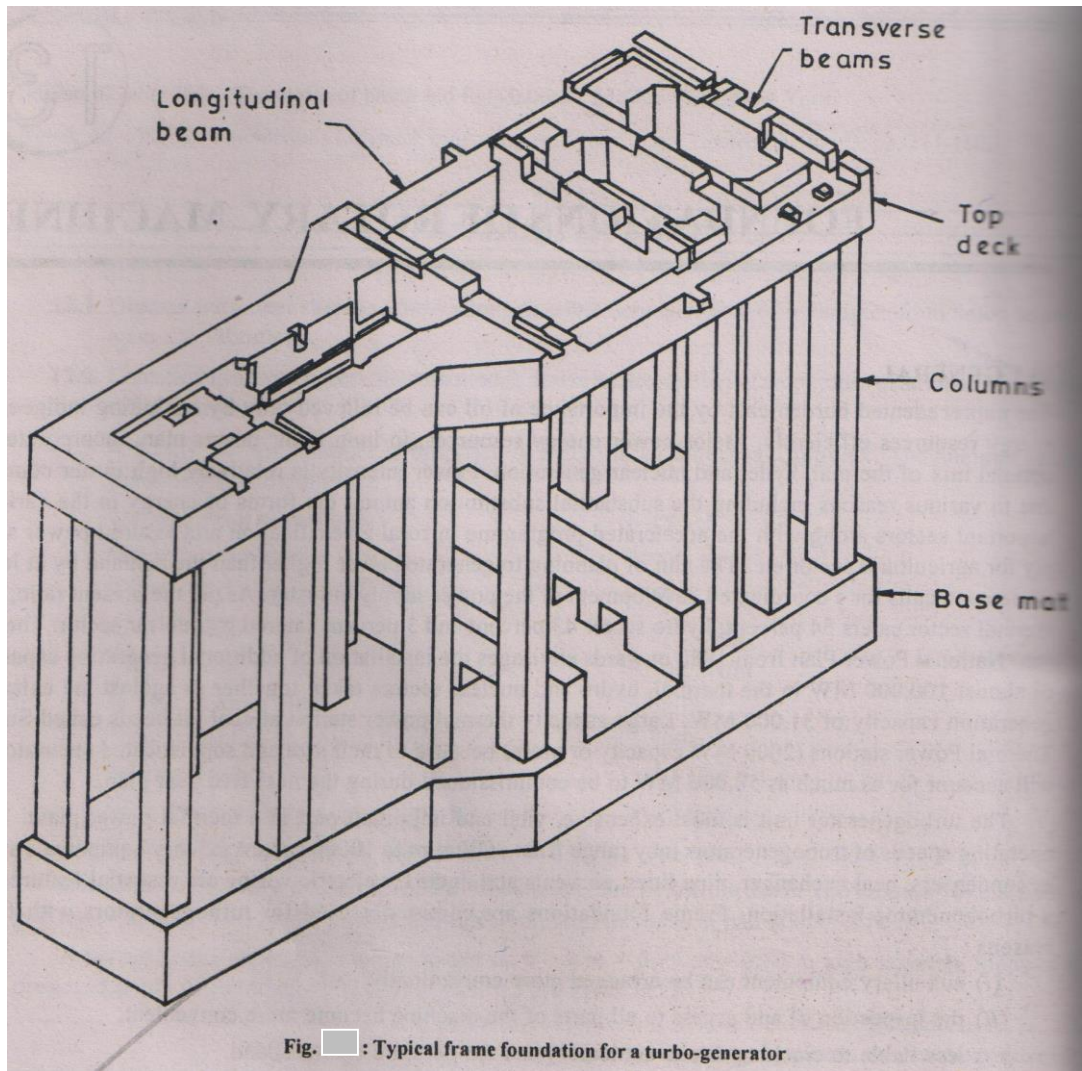

Special considerations:-

For better performance of a T.G. foundation, following points may be kept in view:

- i) The entire foundation should be separated from the main building in order to isolate the transfer of vibrations from the top deck of the foundation to the building floor of the machine room. A clear gap should be provided all round.
- ii) Other footing placed near to the machine foundation should be checked for non-uniform stresses imposed by adjacent footings. The pressure-bulbs under the adjacent footings should not interfere significantly with each other.
- iii) All the junctions of beams and columns of the foundation should be provided with adequate haunches in order to increase the general rigidity of the frame foundation.
- iv) The cross-sectional height of the cantilever elements at the embedment point should not be less than 60 to 75 percent of its span, being susceptible to excessive local vibrations.
- v) The transverse beams should have their axis vertical below the bearing to avoid torsion. For the same reason the axes of columns and transverse beams should lie in the same vertical plane.
- vi) The upper platform should be as rigid as possible in its plane.
- vii) Permissible pressure on soil may be reduced by 20 percent to account for the vibration of the foundation slab. This slab has much smaller amplitudes of vibration than the upper platform.
- viii) The lower foundation slab should be sufficiently rigid to resist non-uniform settlement and heavy enough to lower the common centre of gravity of the machine and foundation. It is therefore made thicker than required by static computations. For 25MV machine its thickness is 2m and increase with the power of the machine to a maximum of 4m. Its weight should not be less than the weight of the machine plus the weight of the foundation excluding the base slab and condensers.
- ix) Special reinforcement detailing as laid down in the code IS-2974 Pt III should be followed.
- x) Special care in construction is called for to avoid cracking of concrete. The foundation slab should be completed in one continuous pouring. In this case the

joint between the two concretes, preferably at one-third column height, is specially treated to ensure 100 percent bond.

- xi) Piles may be provided to meet the bearing capacity requirement but then the consideration of subgrade effect is essential.
- xii) As far as possible the foundation should be dimensioned such that the centre of the gravity of the foundation with the machine should be in vertical alignment with that of the base area in contact with the soil.
- xiii) The ground-water table should be as low as possible and deeper by at least one-fourth of the width of foundation below the base plane. This limits the vibrations propagation, ground-water being a good conductor to wave transmission.
- xiv) Soil-profile and characteristics of soil upto at least thrice the width of the turbine foundation or till hard stratum is reached or upto pile depth, if piles are provided, should be investigated.

Design Criteria:-

The design of a T.G. foundation is based on the following design criteria:-

- i) From the point of view of vibration, the natural frequencies of foundation system should preferably be at a variance of at least 30 percent from the operating speed of the machine as well as critical speeds of the rotor. Thus resonance is avoided. An uncertainty of 10 to 20 percent may be assumed in the computed natural frequencies. However, it may not be necessary to avoid resonance in higher modes, if the resulting resonant amplitude is relatively insignificant.
It is preferable to maintain a frequency separation of 50 percent.
- ii) The amplitudes of vibration should be within permissible limits. Values of permissible amplitude are given in Table.

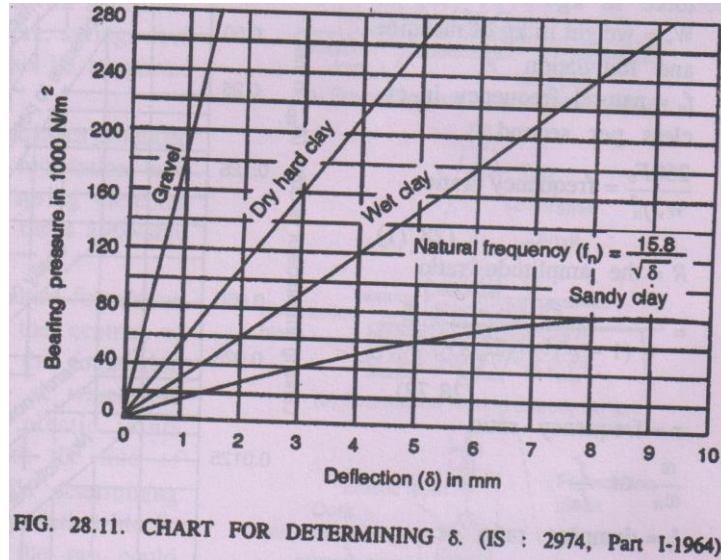

Indian Standard code of Practice for Design of Foundations for Reciprocating Type Machines:-

IS code of practice: (IS: 2974, Part-I : 1964) gives the following criteria:

1. The size of the foundation block (in plan) should be larger than the bed plate of the machine with a minimum allround clearance of 15cm.
2. The width of the foundation should be at least equal to the distance of the centre of gravity of the crank shaft to the bottom of foundation in all vertical machines.
3. The depth of the foundation should be such as to rest the foundation on a good bearing strata and to ensure stability against rotation in a vertical plane.
4. The combined centre of gravity of machine and the foundation block should be as much below the top of the foundation as possible.
5. Whenever possible, the operating frequency should be lower than the natural frequency of the foundation soil system and the frequency ratio should be less than 0.5. When the operating frequency is higher than the natural frequency of the foundation soil system of the machine, the frequency ratio should be more than 2 for important machines and more than 1.5 for others.

Natural frequency:- The natural frequency (cycles per second) under the given stress intensity is given by the following equation: $f_n = \frac{15.8}{\sqrt{\delta}}$

Where δ = elastic deflection of the foundation in millimeters, with respect to the entire area of foundation, to be determined from Fig.

The permissible bearing pressure, for use in Fig. , under dynamic loads may be taken as $\frac{1}{3}$ to $\frac{1}{4}$ of the permissible bearing pressure under static loads.

Amplitude of vibrations:- The permissible amplitude should not exceed the limiting amplitude for the machine prescribed by the manufacturers. Where such data are not available, for relatively unimportant structures, the limiting amplitude should be determined from Fig.

The probable amplitude, in mm, of the machine at the operating frequency, is given by the following expression:

$$A_z = \frac{250F_0}{W_v f_n^2} \cdot R$$

Where F_0 =dynamic force in kg

W_v = weight in kg of machine and foundation

F_n = natural frequency in cycles per second

$\frac{250F_0}{W_v f_n^2}$ = frequency ratio

R- the amplitude ratio

$$= \frac{r^2}{\sqrt{(1-r^2)^2 + (2r)^2}}$$

r= frequency ratio

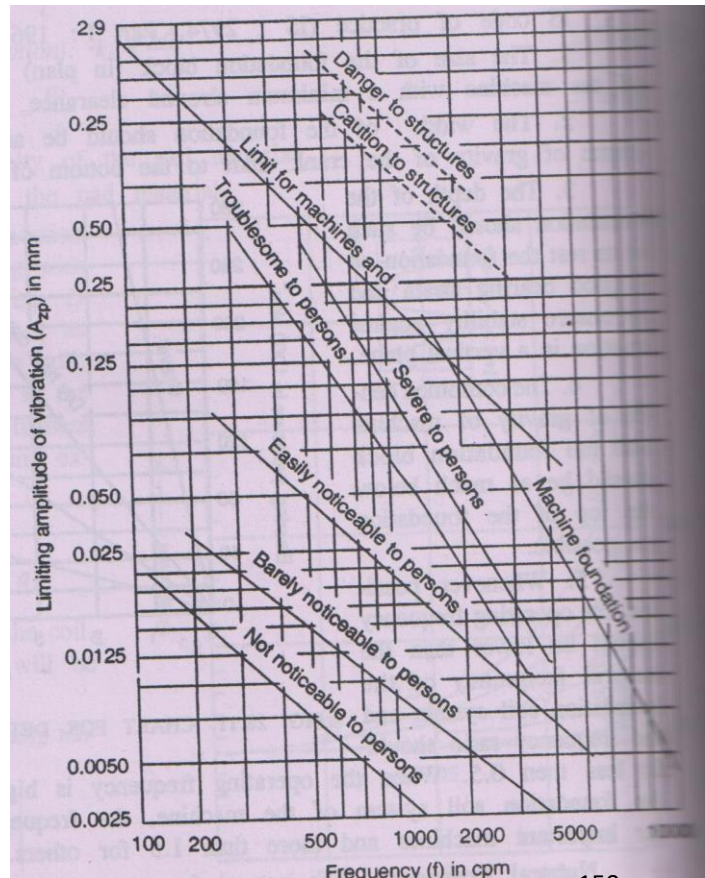

$$\frac{\omega}{\omega_n} \text{ or } \frac{f}{f_n}$$

ϵ = damping ratio or damping factor $\frac{C}{C_c}$

The value of ϵ should be determined from dynamic tests. When the value of ϵ is not provided, it can be taken as 0.25.

Indian Standard code of Practice for Design of Foundations for Impact Type Machines:-

The design requirements of the impact types machines, such as drop and forge hammers, are design than those of the reciprocating type machines, discussed above. IS: 2974 (Part-II) : 1966 covers the design requirements for the foundation of these machines.

Definitions: (i) Anvil: Anvil is a base-block for a hammer on which material is forged into type shape by repeated striking of the tup. (ii) Tup: Tup is a weighted block which strikes the material being forged on the anvil.

(iii) Foundation block: It is a mass of reinforced concrete on which the anvil rests.

(iv) Protective cushioning layer (joint J_1): It is an elastic cushioning of the suitable material and thickness provided between the anvil and the foundation block in order to prevent bouncing of anvil and creation of large impact stresses and consequent damages to the top surface of the concrete in the foundation block.

(v) Foundation support (Joint J_2): It is a

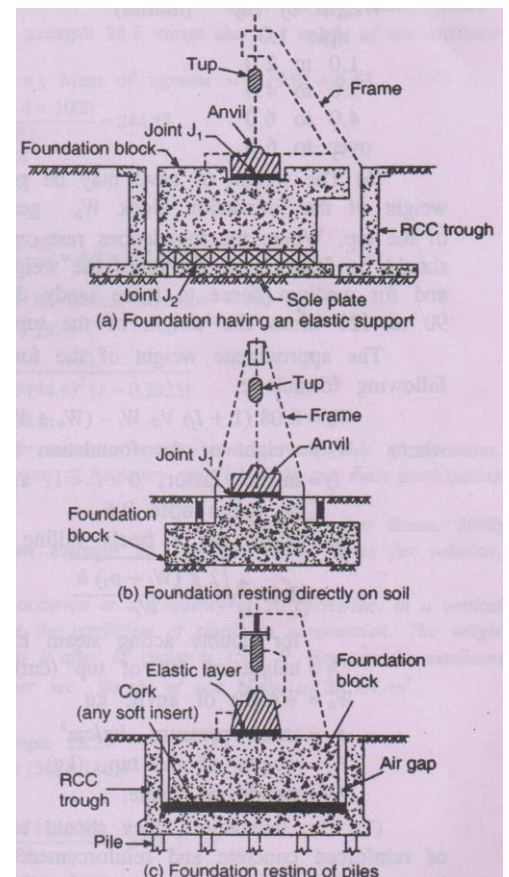

support for resting the foundation block.

The block may rest directly on ground

or on a resilient mounting such as timber sleepers, springs cork layer etc. The block may also be supported on pile foundations.

Design Criteria: (1)- The stresses produced at the time of impact in the foundation base (soil, timber, sleeper, cork, spring elements or piles) should be within 0.8 times allowable static stresses.

(2) The design of the entire foundation system should be such that the centres of gravity of the anvil, and of the foundation block, as well as the joints at which the resultants of forces in the elastic joints J_1 and J_2 act, coincide with the line of fall of the hammer tup. While determining the centre of gravity of the foundation block, the weight of the frame of the tup could also be considered.

(3) The maximum vertical vibrational amplitude of the foundation block should not be more than 1.2mm. In case of foundations on sand below the ground water, the permissible amplitude should not be more than 0.8mm.

(4) For the anvil, the permissible amplitude, which depends upon the weight of the tup should be taken from the following table:

	Weight of tup	Maximum permissible amplitude
Upto	1 t	1 mm
	2t	2mm
More than	3t	3 to 4 mm

(5) The area of foundation block should be such that the safe loading intensity of soil is never exceeded during the operation of the hammer. The depth of the foundation block should be so designed that the block is safe both in punching shear and bending.

Weight of tup (tonnes)	Minimum depth of foundation block
------------------------	-----------------------------------

Upto	1.0 t	1.00m
	1.0 to 2.0	1.25m
	2.0 to 4.0	1.75m
	4.0 to 6.0	2.25m
	Over to 6.0	2.50m

(6) The weight of anvil may be generally kept at 25 times the weight of tup. The weight of the foundation block W_b generally varies from 66 to 120 times the weight of the tup. Where the foundations rest on stiff clays or compact sandy deposits, the weight should be from 75 to 80 times the weight of the tup. For moderately firm to soft clays and for medium dense to loose sandy deposits, the weight of the block should be from 90 to 120 times the weight of the tup.

The approximate weight of the foundation block may also be determined from the following formula:

$$W_b = 0.8 (1 + I_f) V_{tb} W_t - (W_a + W_f) \dots\dots\dots(28.73)$$

Where W_b = weight of the foundation block (kg)

I_f = impact factor, $0 < I_f < 1$, and its average value for design purpose may be taken upto 0.6

$$V_{tb} = \sqrt{2gh} \text{ for a freely falling tup type hammer}$$

$$= 0.65 \sqrt{\frac{2g(W_t + P_s)h}{W_t}}$$

For double acting steam hammers

H = height of fall of tup (cm)

W_a = weight of anvil, kg

P_s = steam pressure, kg/cm²

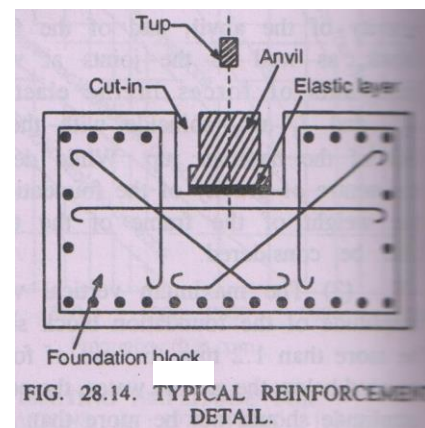

W_t = weight of the tup, (kg)

W_f = weight of fram.

(7) The foundation block should be made of reinforced concrete and reinforcement should be arranged along the three axes and also diagonally to prevent shear, as shown in Fig. 28.14. More reinforcement should be provided at the top side of the foundation block than at the other side. Reinforcement at the top may be provided in the form of layers of grills made of 16mm diameter bars suitably spaced to allow easy pouring of concrete. The reinforcement provided should be at least 25kg per m^3 of concrete.

VIBRATION ISOLATION AND SCREENING

General:-

In machine foundations, following two types of the problems may arise:

- i) Machines directly mounted on foundation block may cause objectionable vibrations.
- ii) Machine foundation suffers excessive amplitude due to the vibrations transmitted from the neighbouring machines.

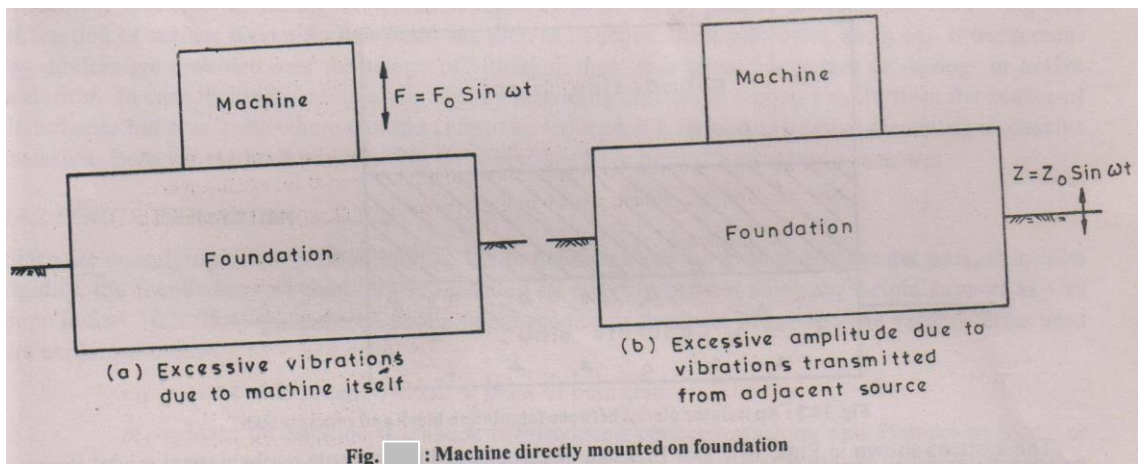

The first problem may be tackled by isolating the machines from the foundation through a suitably designed mounting system such that the transmitted force is reduced which in turn will reduce the amplitude. This type of isolation is termed as force isolation. This type of arrangement will pose is termed as motion isolation. For heavier machines, the isolating system may be placed between the foundation block and concrete slab as shown in Fig. Here

the machine are rigidly bolted to the foundation block which is isolated from the concrete slab through the mounting system. The mounting system is an elastic layer which may be in the form of rubber pad, timber pad, cork pad or metal springs.

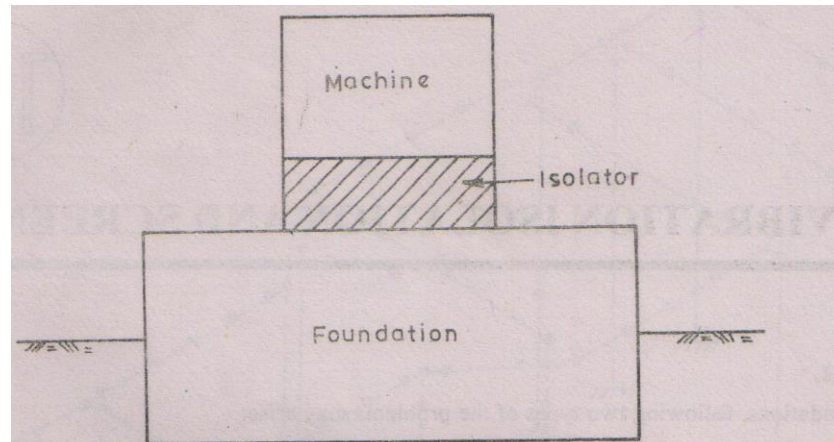

Fig. 14.2 : An isolator placed between machine and foundation

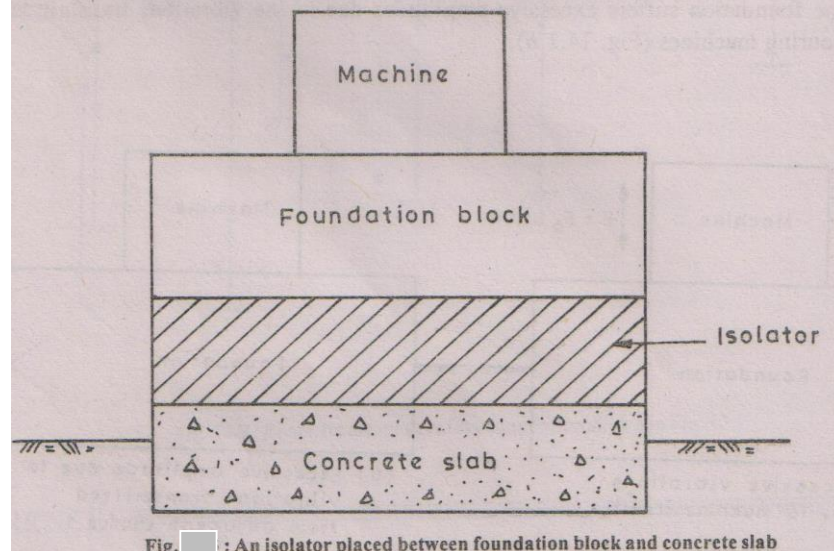
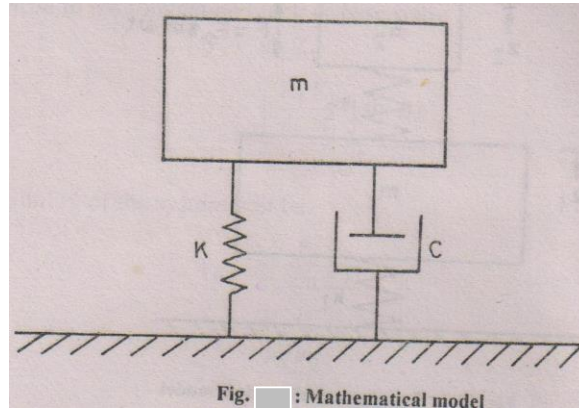

Fig. : An isolator placed between foundation block and concrete slab

The systems shown in Fig. can be represented by a simple mathematical model shown in Fig. In this m represents the mass of machine or mass of machine plus foundation block. The mounting system (i.e. the elastic layer) is characterised by a linear spring with a spring constant K and dashpot with damping constant C . This mathematical representation involves one basic assumption that the underlying soil or rock possesses infinite rigidity. This system is identical to the one shown in Fig. and the detailed analysis has already been presented considering both force isolation and motion isolation separately.



A more realistic model will be that in which the soil or rock is considered as an elastic medium. This will make the system as a two-degree-freedom problem, the solutions of which are presented in the next section.

The second problem in which the vibration are transmitted from the neighbouring machines can be solved by controlling the vibrating energy reaching the desired location. This is referred to as vibration screening. Effective screening of vibration may be achieved by proper interception. Scattering, and diffraction of surface waves by using barriers such as trenches, sheet-pile walls, and piles. If the screening devices are provided near the source of vibration, then it is termed as active screening or active isolation. In case screening devices are used by providing barriers at a point remote from the source of disturbance but near a site where vibration has to be reduced, it is termed as passive screening or passive isolation. Both the methods of screening the vibrations have been discussed subsequently.

Force Isolation:-

Since the underlying soil or rock supporting the foundation block (or base slab) does not possess infinite rigidity, the foundation soil should be represented by a spring and not solely by a rigid support. Then the mathematical model becomes as shown in Fig. The various terms used are explained below:

m_1 = Mass of foundation block or mass of base slab

m_2 = Mass of machines if isolator is introduced between machine and foundation block or mass of machine plus mass of foundation block if isolator is placed between foundation block and mass slab.

$K_1 =$ Stiffness of the soil

$K_2 =$ Stiffness of the isolator

Screening of Vibrations by use of open Trenches:-

Active Screening: In this case the screening of vibrations is done near the source of vibration. Figure shows a circular trench of radius R and depth H which surrounds the machine foundation that is the source of disturbance. The design of trench barriers is based on some field observations. Barkan (1962) mentioned that the reduction in vibration amplitude occurs only when the trench dimensions are sufficiently large compared with the wave length of the surface waves generated by the source of disturbance. Dolling (1966) studied the effect of size and shape of the trench on its ability to screen the vibrations.

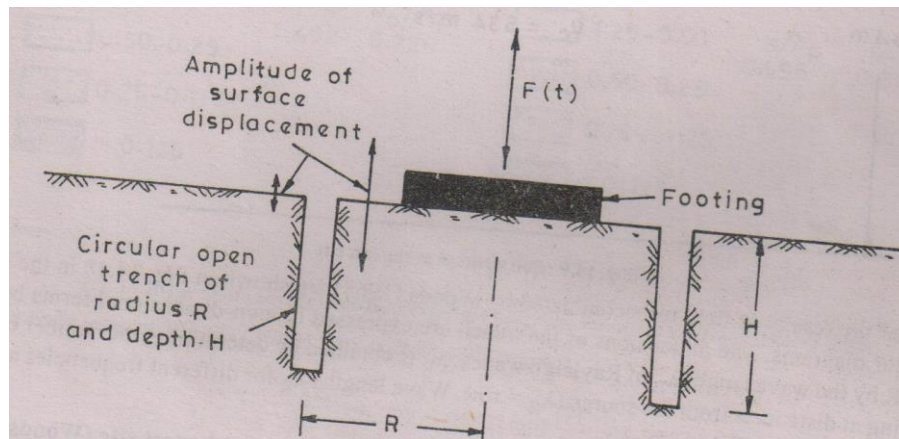

The first comprehensive study of screening vibration by use of open trench was made by Woods and Richarts (1967) and Woods (1968). They conducted field tests by creating vertical vibrations with a small vibrator resting on a small pad at a prepared site. The vibrator could create a maximum force of 80N. The soil conditions at the site were as shown in Fig. 14.9. The water table was below 14.3m depth. The depth H of trenches was varied from 150mm to 600mm, the radius R of annular trench varied from 150mm to 300mm, and the angular dimension θ was varied from 90° to 360° around the source of vibration. Frequencies of 200 to 350 Hz were used in the tests. Using velocity transducers, the amplitudes of vertical ground motion were measured at selected points throughout the test site before installation of the trench and after installation of the trench. Woods (1968) has introduced a term amplitude reduction factor which is defined as

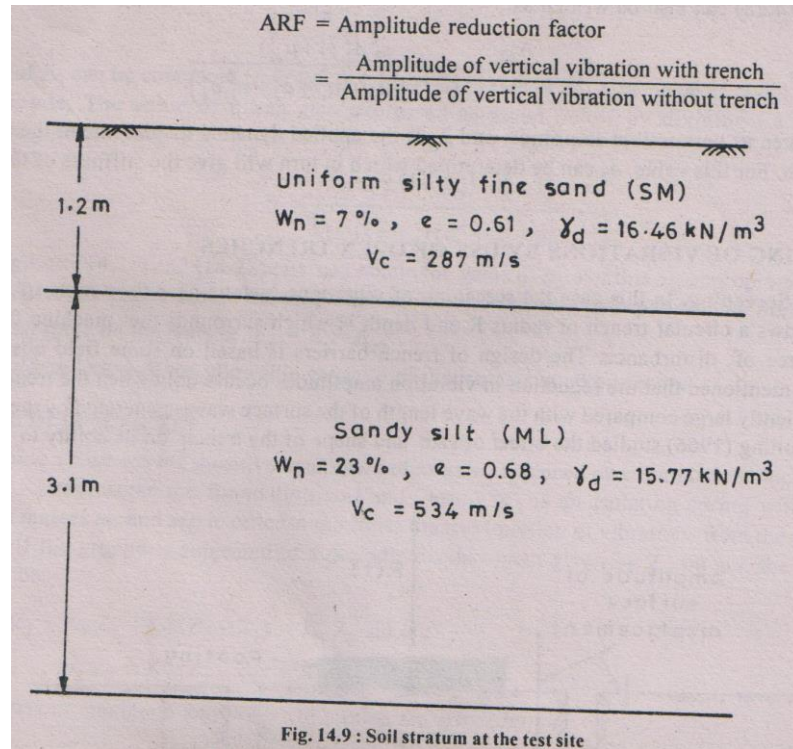

Some of the results of field tests conducted by Woods (1968) are shown in Fig. in the form of ARF contour diagrams. The dimensions of the trench are expressed in non-dimensional forms by dividing H and R by the wave length λ_R of Rayleigh waves. λ_R is obtained by determining the number of waves (n) occurring at distance x from the source ($\lambda_R = x/n$). Wave lengths λ_R for different frequencies are given in Table .

Table -Wavelength and wave velocity for the Rayleigh wave at the test site (Woods, 1968)

Frequency Hz	λ_R mm	V_R m/x
200	687	137
250	513	128
300	421	126
350	336	117

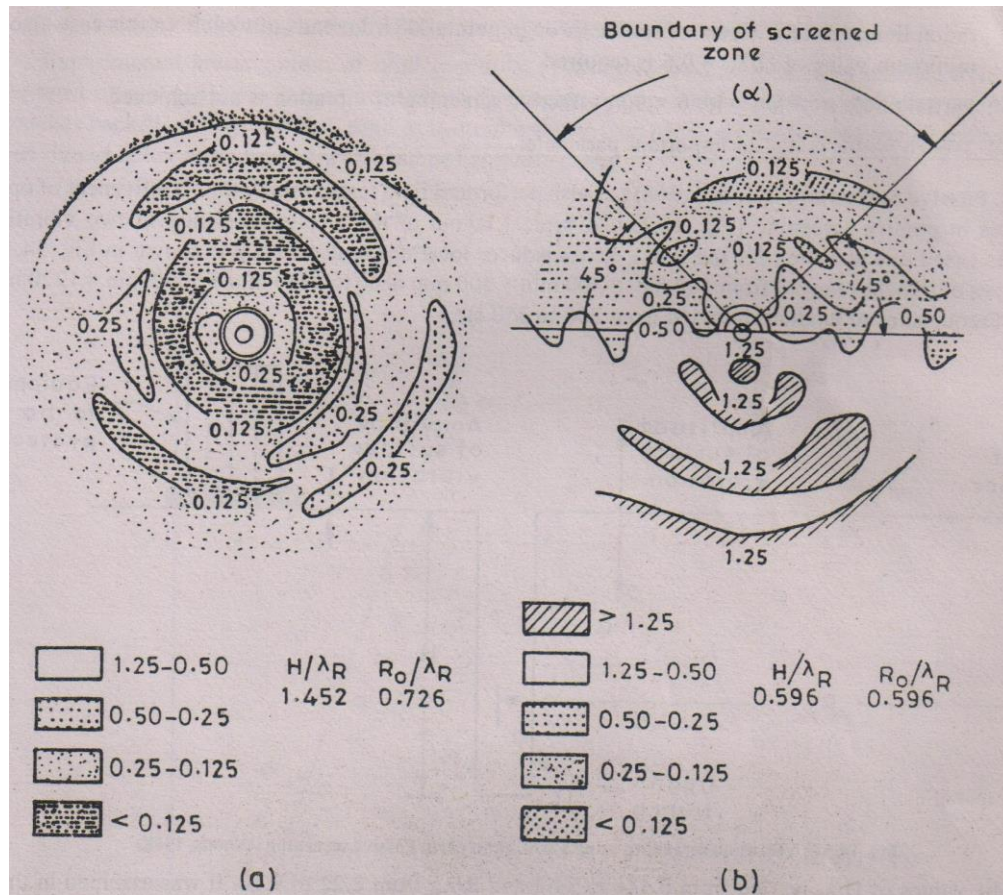

The field tests of Woods (1968) thus correspond to

$$\frac{H}{R} = 0.222 - 0.910 \text{ and } \frac{H}{R} = 0.222 - 1.82$$

For satisfactory screening of vibration, Woods (1968) recommended that ARF should be less than or equal to 0.25. The conclusions made on the basis of this study to keep ARF ≤ 0.25 are:

- i) For full circle trenches ($\theta = 360^\circ$), a minimum value of $H/\lambda_R = 0.6$ is required. The zone screened in this case extended to a distance of at least 10 wave lengths ($10\lambda_R$) from the source of disturbance.
- ii) For partial circle trenches ($90^\circ < \theta < 360^\circ$), the screened zone was defined as an area outside the trench extending to at least 10 wave lengths ($10\lambda_R$) from the source and bounded on the sides by radial lines from the centre of source through points 45° from ends of trench. In this case also, a minimum value of $(H/\lambda_R) = 0.6$ is required.

- iii) Partial circle trenches with $\theta < 90^\circ$, effective screening of vibration is not achieved.
- iv) Trench width is not an important parameter.

Passive Screening:- Woods (1968) has also performed field tests to study the effectiveness of open trenches in passive screening. A typical layout of these test consisting of two vibration exciters (used one at a time for the tests), 75t transducer location, and a trench is shown in Fig. The sizes of trenches ranged from 100mmx300mm mm deep to 2440 mmx3050mmx1220mm deep. Frequencies of excitation varied form 200 to 350Hz.

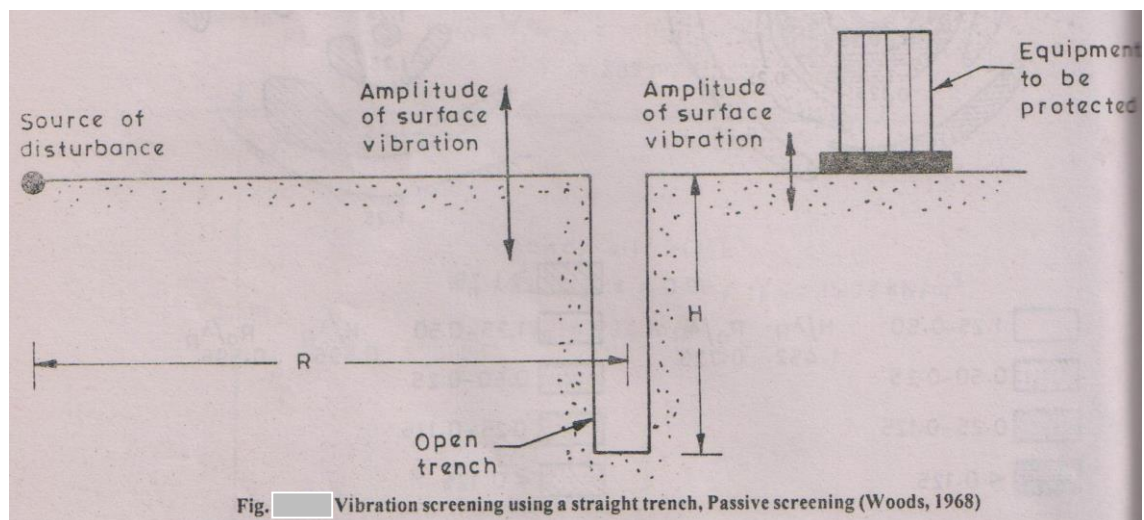

The values of H/λ_R varied from 0.444 to 3.64 and R/λ_R from 2.22 to 9.10. It was assumed in these tests that the zones screened by the trench would be symmetrical about the 0° line. Figure shows the ARF contour diagram for one of these tests.

For satisfactory screening, Woods (1968) recommended that the ARF should be less than or equal to 0.25 in a semi-circular zone of radius $(1/2) L$ behind the trench. The conclusions made on the basis of this field study to keep $ARF \leq 0.25$ are:

- i) H/λ_R should be atleast 1.33
- ii) To maintain the same degree of screening, the least area of the trench in the vertical direction (i.e. $LH-A_T$), should be as follows:

$$\frac{A_T}{\lambda_R^2} = 2.5 \text{ at } \frac{R}{\lambda_R} = 2.0$$

And

$$\frac{A_T}{\lambda_R^2} = 6.0 \text{ at } \frac{R}{\lambda_R} = 7.0$$

iii) Trench width had practically no influence on the effectiveness of screening.

Experimental investigations of Sridharan et. al (1981) indicated that the open unfilled trenches are the most effective. However, the open (unfilled) trenches may present instability problems necessitating trenches backfilled with sawdust, sand or bentonite slurry. The performance of open trench with sawdust was found better as compared with sand or bentonite slurry.

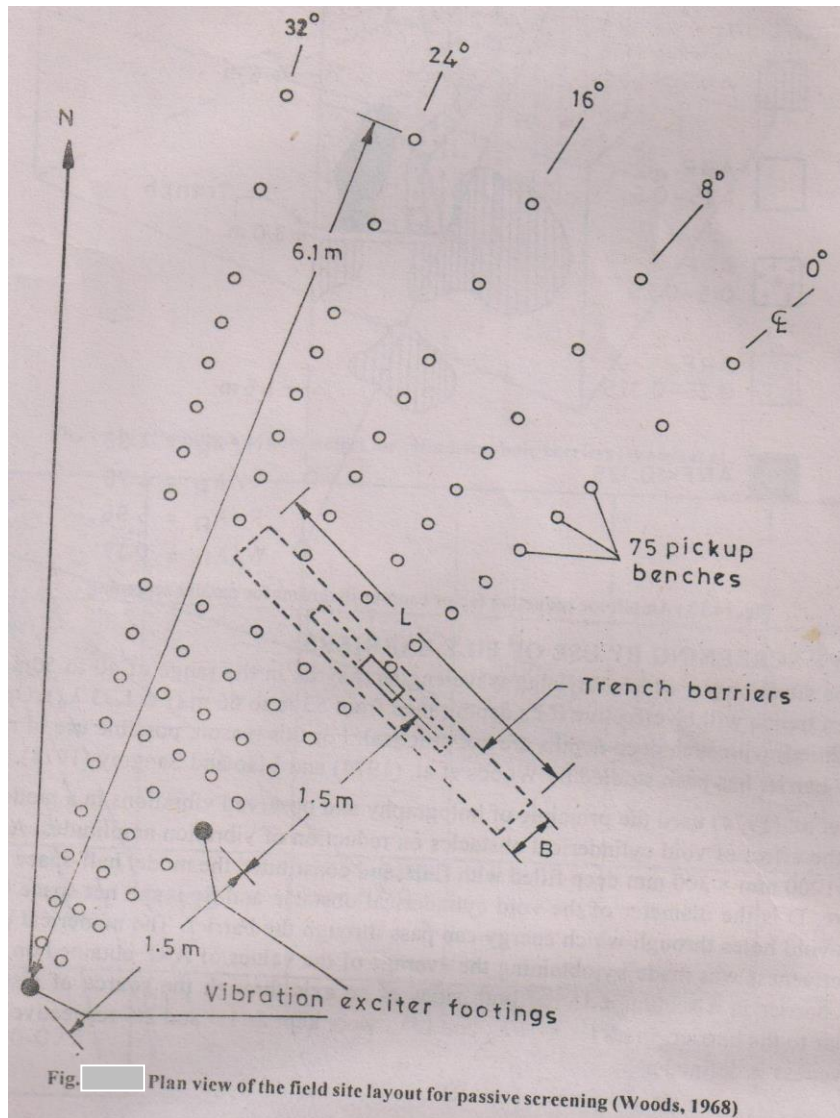

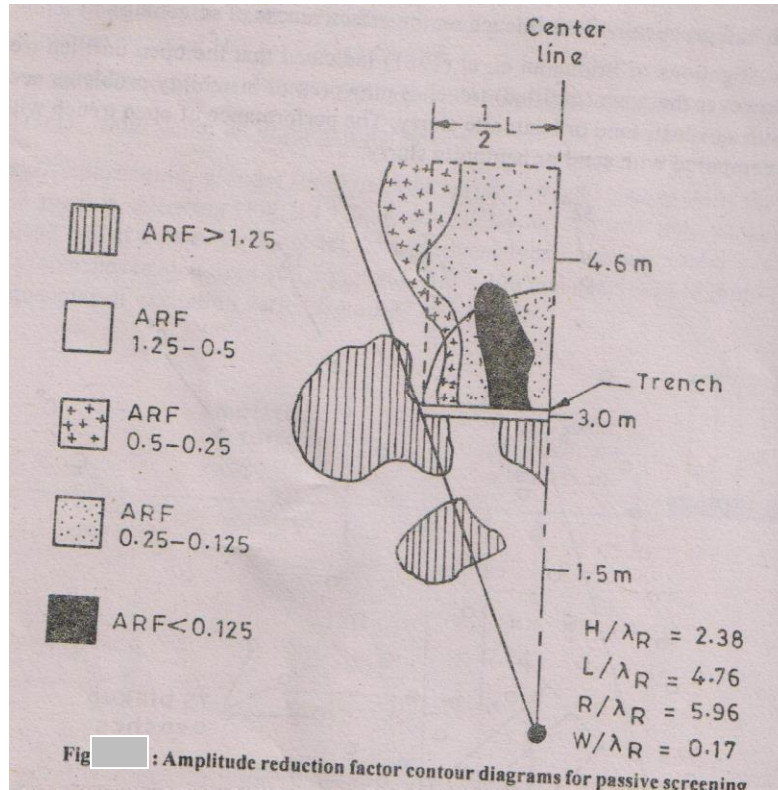

Passive Screening by use of Pile Barriers:-

There may be situations in which Rayleigh wavelengths may be in the range of 40 to 50m. For such a case, the open trench will be effective if its depth range from 53m to 66m (i.e. $1.33 \lambda_R$). Open trenches (filled or unfilled) with such deep depths are not practical. For this reason, possible use of rows of piles as an energy barrier has been studied by Woods et al. (1974) and Liao and Sangery (1978).

Woods et. al (1974) used the principle of holography and observed vibrations in a model half-space to evaluate the effect of void cylindrical obstacles on reduction of vibration amplitude. A box of size 1000mmx1000mmx300mm deep filled with fine sand constituted the model half-space. In this figure, D is the diameter of the void cylindrical obstacle and S_n is the net space between two consecutive void holes through which energy can pass through the barrier. The numerical evaluation of barrier effectiveness was made by obtaining the average of the values of ARF obtained on several lines beyond the barrier in a section $\pm 15^\circ$ of both sides of an axis through the source of disturbance and perpendicular to the barrier. In all tests, H/λ_R and L/λ_R were kept as 1.4 and 2.5 respectively. The isolation effectiveness is defined as

Effectiveness = 1 - ARF

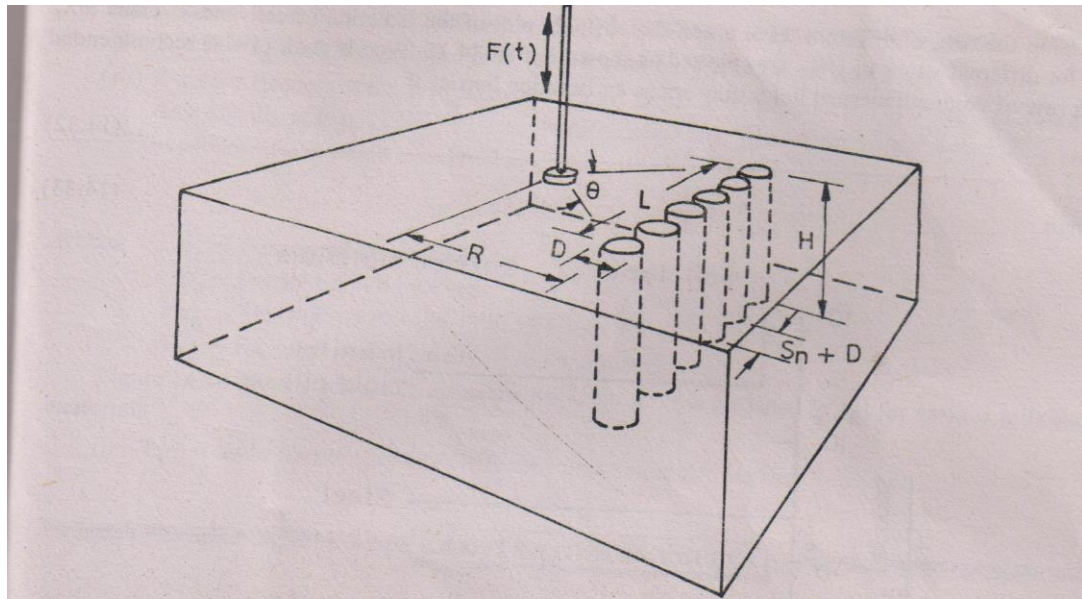

Fig. 14.14 : Definition of parameters for cylindrical hole barriers (Woods et al., 1974)

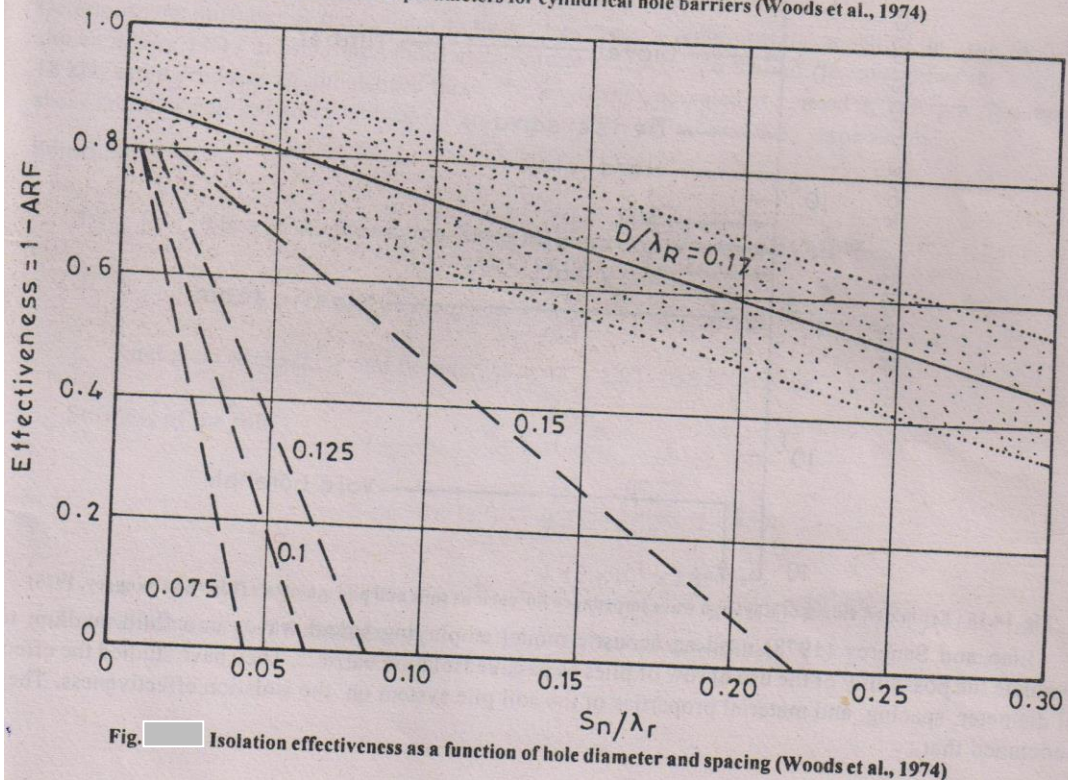

Fig. Isolation effectiveness as a function of hole diameter and spacing (Woods et al., 1974)

Using the data of different tests, a non-dimensional plot of the isolation effectiveness versus S/λ_R ratio for different values of D/λ_R was plotted as shown in Fig. Woods et al. (1974) recommended that a row of void cylindrical holes may act as an isolation barrier if

$$\frac{D}{R} \geq \frac{1}{6}$$

And

$$\frac{E_p}{R} < \frac{1}{4}$$

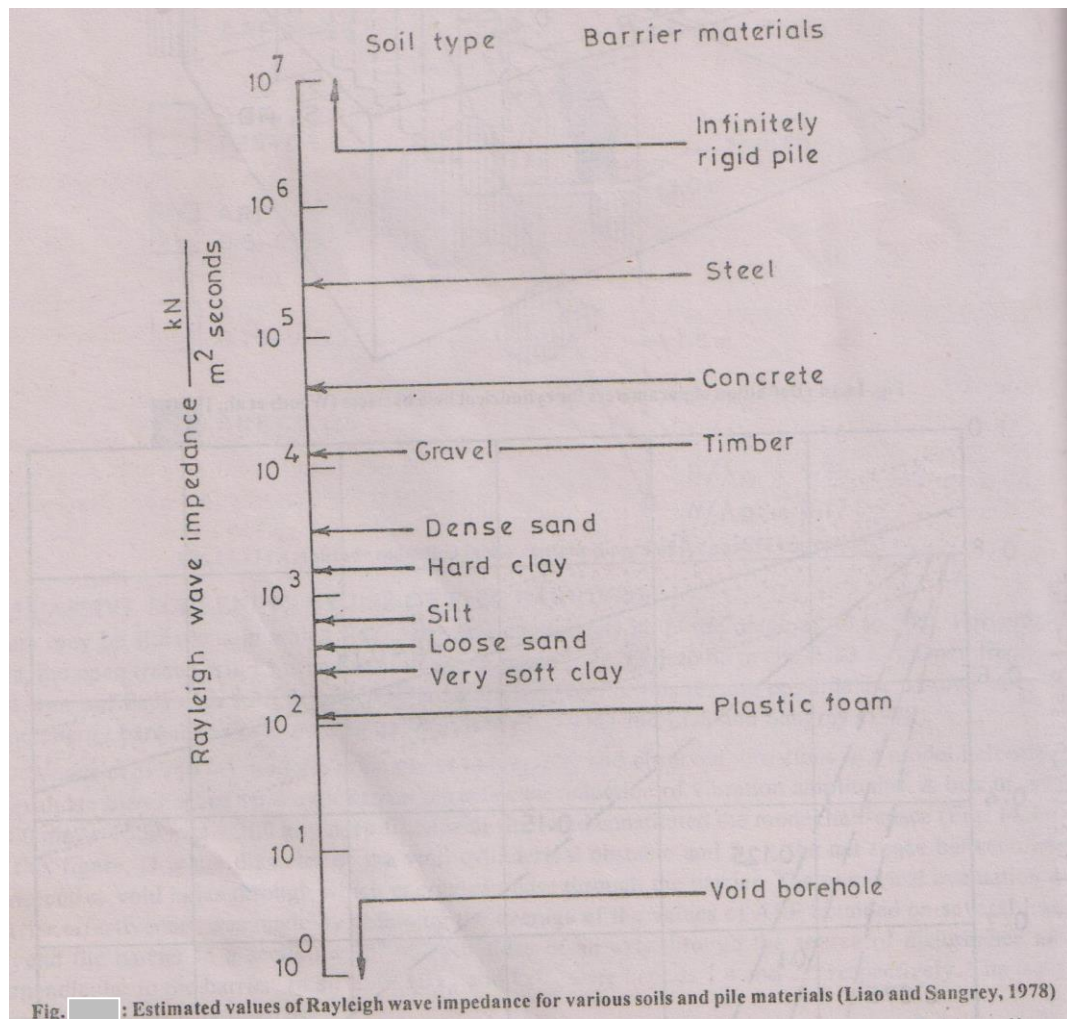

Liao and Sangrey (1978) used an acoustic model employing sound waves in a fluid medium to evaluate the possibility of the use of row of piles as passive isolation barriers. They have studied the effect of diameter, spacing and material properties of the soil pile system on the isolation effectiveness. They concluded that:

- i) The Eqs. proposed by Woods et al (1974) are generally valid.

- ii) $S_n = 0.4 \lambda_R$ may be the upper limit for a barrier to have some effectiveness.
- iii) The effectiveness of the barrier is significantly affected by the material of the pile and void holes. Acoustically soft piles ($IR < 1$) are more efficient than acoustically hard piles ($IR > 1$). IR is impedance ratio which is defined as

$$IR = \frac{P_p V_{RP}}{P_s V_{RS}}$$

Where, P_p = Density of pile material

P_s = Density of soil medium

V_{RP} = Rayleigh wave velocity in pile material

V_{RS} = Rayleigh wave velocity in soil medium

Figure gives a general range of the Rayleigh wave impedance (ρV_R) for various soils and pile materials.

- iv) Two rows of barriers are more effective than single row barriers.